

LECTURE NOTES
ON
ESTIMATION AND COSTING
(A70138)

IV B. Tech I Semester (JNTUH-R15)

By

Mr. Gude Ramakrishna
Associate Professor



DEPARTMENT OF CIVIL ENGINEERING
INSTITUTE OF AERONAUTICAL ENGINEERING
(Autonomous)
DUNDIGAL, HYDERABAD - 500 043

UNIT - I

INTRODUCTION

TECHNICAL TERMS

1. ESTIMATE:An estimate is the anticipated or probable cost of work and is usually prepared before the construction is taken up. It is indeed calculations or computations of various items of an engineering work.

2. QUANTITY SURVEY: It is the schedule of all items of work in a building. These quantities are calculated from the drawing of the building. Thus quantity survey gives quantities of work done in case of each items, when priced gives the total cost. In short, quantity survey means calculations of quantities of materials required to complete the work concerned

3.SPECIFICATIONS :Detailed specifications gives the nature, quality and class of work, materials to be used in the various parts of work , quality of the material, their proportions, method of preparation, workmanship and description of execution of work are required.

4.RATES :The rates of various items of works, materials to be used in the construction and the wages of different categories of labor (skilled and unskilled) should be available for preparing an estimate. The cost of transportation charges should also be known. As far as possible sanctioned "Schedule of Rates" shall be followed or the rates may be worked out by the "Analysis of Rates" method.

5.SITE PLAN: It is the plan drawn for a particular construction showing its position with respect to approaching roads, main bazars, markets and other permanent features in a populated area. It shows the location of the area under construction with respect to the other areas and on it generally the names of the owners of areas or property holders adjoining to it are also denoted. North line is also clearly marked on it.

6. LINE PLAN Line plan can be defined as the plan of a particular construction simply showing main features with the help of the single lines of different portions of the constructions. Details of constructions are not generally shown on this plan. This inside and outside dimensions shown on this plan should necessarily be corresponding to actual dimensions.

7. INDEX PLAN :This is the plan of a particular colony showing the positions of different houses in single lines their number if any position of roads, schools, market, hospitals and other features etc. this plan is generally fixed on the entrance, or at exit or in the central place of the colony, for the guidance of the inhabitants and outsiders.

DETAILED PLAN : This plan indicates a plan of a construction drawn to a definite scale, showing all detailed information required for its execution. Various sections and elevations are clearly drawn on this plan.

CENTRE LINE PLAN : This is actually a layout plan drawn to facilitate the laying out of foundation lines and other features. It is generally fixed on the entrance or at exit in the central place of the colony for the guidance of the inhabitants and outsiders.

SUPPLEMENTARY ESTIMATE: When some additions are done in the original work, a fresh detailed estimate is prepared to supplement the original work. This estimate is called supplementary estimate. It is also accompanied by all the papers as required in thru detailed estimate.

ADMINISTRATIVE APPROVAL: For any project required by the department an approval so sanction of the competent authority with respect to the cost and work is necessary at the first instance. Thus administrative approval denotes the formal acceptance by the administrative department concerned of the proposals for incurring expenditure.

TECHNICAL SANCTION :It means the sanction and order by the competent authority of the department for the detailed estimate design calculations quantities of work rates and cost of work..after the technical sanction of the estimate is received the work is then taken up for construction.

COMPETENT AUTHORITY: An officer or any other authority in the department to whom relevant powers are delegated by the government (Financial Department).

ORDINARY MEASUREMENT BOOK: It is measured book in which entries regarding the work done or supplies made and services performed are recorded for the purpose of making payments to the contractors or the labor. Entries in the M.B are generally recorded by the sectional officers or by any other officers deputed for the purpose

LUMPSUM ITEMS

Sometimes while preparing estimate for the certain small items like front architecture or decoration work of a building it is not possible to workout detailed quantities so far such lump sum items a lump sum rate is provided.

PLINTH AREA

The built up covered area of a building measured at floor level of any storey is called plinth area.

17. CIRCULATION AREA

The total cost of construction including all expenditures incurred plus the cost of external services up to the end of the completion of the work is called capital cost. It also includes the cost of preliminary works, miscellaneous items and supervision charges etc.

1.1 GENERAL

Estimating is the technique of calculating or computing the various quantities and the expected Expenditure to be incurred on a particular work or project. In case the funds available are less than the estimated cost the work is done in part or by reducing it or specifications are altered, the following requirements are necessary for preparing an estimate.

1. Drawings like plan, elevation and sections of important points.
2. Detailed specifications about workmanship & properties of materials etc.
3. Standard schedule of rates of the current year.

1.2 UNITS OF MEASUREMENTS

The units of measurements are mainly categorized for their nature, shape and size and for making payments to the contractor and also. The principle of units of measurements normally consists the following:

- a) Single units work like doors, windows, trusses etc., is expressed in numbers.
- b) Works consists linear measurements involve length like cornice, fencing, hand rail, bands of specified width etc., are expressed in running meters (RM)
- c) Works consists areal surface measurements involve area like plastering, white washing, partitions of specified thickness etc., and are expressed in square meters (m²)
- d) Works consists cubical contents which involve volume like earth work, cement concrete, Masonry etc are expressed in Cubic metres.

[BASED ON IS 1200 REVISED]

Sl. No.	Particulars of item	Units of Measurement	Units of payment
I	Earth work:		
	1. Earth work in Excavation	cum	Per%cum
	2. Earthwork in filling in foundation trenches	cum	Per%cum
II	3. Earth work in filling in plinth	cum	Per%cum
	Concrete:		
	1. Lime concrete in foundation	cum	percum
	2. Cement concrete in Lintels	cum	percum

	6. Cement concrete bed	cum	per cum
	7. R.C. Sunshade (Specified Width & Hight)	cum	1m
III	Damp Proof Course (D.P.C) (Thickness should be mentioned)	sqm	persqm
IV	Brick work:		
	1. Brickwork in foundation	cum	percum
	2. Brick work in plinth	cum	percum
	3. Brick work in super structure	cum	percum
	4. Thin partition walls	sqm	percum
	5. Brick work in arches	cum	percum
V	6. Reinforced brick work (R.B. Work)	cum	percum
	Stone Work: Stone masonry	cum	percum
VI	Wood work:		
	1. Door sand windows frames or chowkhats, rafters beams	cum	percum
	2. Shutters of doors and windows (thickness specified)	sqm	persqm
	3. Doors and windows fittings (like hinges, tower bolts, sliding bolts, handles)	Number	per number
VII	Steel work		
	1. Steel reinforcement bars etc in R.C.C. and R.B.work. quintal	Quintal	per quintal
	2. Bending, binding of steel Reinforcement	Quintal	per quintal
	3. Rivets, bolts, & nuts, Anchor bolts, Lewis bolts, Holding down bolts.	Quintal	per quintal
	4. Iron hold fasts	Quintal	per quintal
	5. Iron railing (height and types specified)	Quintal	per quintal
	6. Iron grills	sqm	per sqm

VIII	Roofing		
	1. R.C.C. and R.B.Slab roof (excluding steel)	cum	per cum
	2. L.C. roof over and inclusive of tiles or brick or stone slab etc (thickness specified)	sqm	per sqm
	3. Centering and shuttering form work	sqm	per sqm
IX	4. A.C. Sheet roofing	sqm	per sqm
	Plastering, points&finishing		
	1. Plastering-Cement or Lime Mortar (thickness and proportion specified)	sqm	per sqm
	2. Pointing	sqm	per sqm
	3. White washing, colour washing, cement wash (number of coats specified)	sqm	per sqm
X	4. Distempering (number of coats specified)	sqm	per sqm
	5. Painting, varnishing (number of coats specified)	sqm	per sqm
	Flooring		
	1. 25mm cement concrete over 75mm lime concrete floor (including L.C.)	sqm	per sqm
	2. 25mm or 40mm C.C. floor	sqm	per sqm
XI	3. Doors and window sills (C.C. or cement mortar plain)	sqm	per sqm
	Rain water pipe /Plain pipe	1RM	per RM
XII	Steel wooden trusses	1No	per 1No
XIII	Glass pannels(supply)	sqm	per sqm
XIV	Fixing of glass panels or cleaning	No	per no.

1.2.1 RULES FOR MEASUREMENT

The rules for measurement of each item are invariably described in IS- 1200.

However some of the general rules are listed below.

1. Measurement shall be made for finished item of work and description of each item shall include materials, transport, labor, fabrication tools and plant and all types of overheads for finishing the work in required shape, size and specification.
2. In booking, the order shall be in sequence of length, breadth and height or thickness.

3. All works shall be measured subject to the following tolerances.
 - I. linear measurement shall be measured to the nearest 0.01m.
 - II. Areas shall be measured to the nearest 0.01 sq.m
 - III. Cubic contents shall be worked-out to the nearest 0.01 cum
4. Same type of work under different conditions and nature shall be measured separately under separate items.
5. The bill of quantities shall fully describe the materials, proportions, workmanships and accurately represent the work to be executed.
6. In case of masonry (stone or brick) or structural concrete, the categories shall be measured separately and the heights shall be described:
 - a) From foundation to plinth level
 - b) From plinth level to first floor level
 - c) From First floor to second floor level and so on.

1.3 REQUIREMENTS OF ESTIMATION AND COSTING

1. Estimate gives an idea of the cost of the work and hence its feasibility can be determined i.e. whether the project could be taken up with in the funds available or not.
2. Estimate gives an idea of time required for the completion of the work.
3. Estimate is required to invite the tenders and Quotations and to arrange contract.
4. Estimate is also required to control the expenditure during the execution of work.
5. Estimate decides whether the proposed plan matches the funds available or not.

1.3.1 PROCEDURE OF ESTIMATING OR METHOD OF ESTIMATING.

Estimating involves the following operations

1. Preparing detailed Estimate.
2. Calculating the rate of each unit of work
3. Preparing abstract of estimate

1.3.2 DATA REQUIRED TO PREPARE AN ESTIMATE

1. Drawings i.e. plans, elevations, sections etc.

2. Specifications.

3. Rates.

1.3.3 DRAWINGS

If the drawings are not clear and without complete dimensions the preparation of estimation become very difficult. So, it is very essential before preparing an estimate.

1.3.4 SPECIFICATIONS

General Specifications: This gives the nature, quality, class and work and materials in general terms to be used in various parts of wok. It helps no form a general idea of building.

Detailed Specifications: These gives the detailed description of the various items of work laying down the Quantities and qualities of materials, their proportions, the method of preparation workmanship and execution of work.

1.3.5 RATES

For preparing the estimate the unit rates of each item of work are required.

1. for arriving at the unit rates of each item.
2. The rates of various materials to be used in the construction.
3. The cost of transport materials.
4. The wages of labor, skilled or unskilled of masons, carpenters, Amador, etc.,

1.3.6 COMPLETE ESTIMATE

Most of people think that the estimate of a structure includes cost of land, cost of materials and labor, but many other direct and indirect costs included and are shown below.

L.S.Items.

The following are some of L.S. Items in the estimate.

1. Water supply and sanitary arrangements.
2. Electrical installations like meter, motor, etc.,
3. Architectural features.
4. Contingencies and unforeseen items.

In general, certain percentage on the cost of estimation is allotted for the above L.S.Items Even if sub estimates prepared or at the end of execution of work, the actual cost should not exceed the L.S.amounts provided in the main estimate.

1.3.8 WORK CHARGED ESTABLISHMENT:

During the construction of a project considerable number of skilled supervisors, work assistance, watch men etc., are employed on temporary basis. The salaries of these persons are drawn from the L.S. amount allotted towards the work charged establishment. That is, establishment which is charged directly to work. An L.S.amount of 1½ to 2% of the estimated cost is provided towards the work charged establishment.

1.4 METHODS OF TAKING OUT QUANTITIES

The quantities like earth work, foundation concrete, brickwork in plinth and super structure etc., can be worked out by any of the following two methods:

- a) Long wall - short wall method
- b) Centre line method.
- c) Partly centre line and short wall method.

1.4.1 LONG WALL-SHORT WALL METHOD

In this method, the wall along the length of room is considered to be long wall while the wall perpendicular to long wall is said to be short wall. To get the length of long wall or short wall, calculate first the centre line lengths of individual walls. Then the length of long wall, (out to out) may be calculated after adding half breadth at each end to its centre line length. Thus the length of short wall

Measured into in and may be found by deducting half breadth from its centre line length at each end. The length of long wall usually decreases from earth work to brick work in super structure while the short wall increases. These lengths are multiplied by breadth and depth to get quantities.

1.4.2 CENTRE LINE METHOD

This method is suitable for walls of similar cross sections. Here the total centre line length is multiplied by breadth and depth of respective item to get the total quantity at a time.

When cross walls or partitions or verandah walls join with main wall, the centre line length gets reduced by half of breadth for each junction. Such junction or joints are studied carefully while calculating total centre line length. The estimates prepared by this method are most accurate and quick.

1.4.3 PARTLY CENTRE LINE AND PARTLY CROSS WALL METHOD

This method is adopted when external (i.e., around the building) wall is of one thickness and the internal walls having different thicknesses. In such cases, centre line method is applied to external walls and long wall-short wall method is used to internal walls. This method suits for different thicknesses walls and different level of foundations. Because of this reason, all Engineering departments are practicing this method.

1.4.4 DETAILED ESTIMATE

The preparation of detailed estimate consists of working out quantities of various items of work and then determines the cost of each item. This is prepared in two stages.

I) DETAILS OF MEASUREMENTS AND CALCULATION OF QUANTITIES

The complete work is divided into various items of work such as earth work concreting, brick work, R.C.C. Plastering etc., The details of measurements are taken from drawings and entered in respective columns of prescribed preformed. The quantities are calculated by multiplying the values that are in numbers column to Depth column as shown below:

Details of measurements form

ii)

S.No	Description of Item	No	Length (L) m	Breadth (B) m	Depth/Height (D/H) m	Quantity	Explanatory Notes

Abstract of Estimated Cost:

The cost of each item of work is worked out from the quantities that already computed in the details measurement form at workable rate. But the total cost is worked out in the prescribed form is known as

abstract of estimated form. 4% of estimated Cost is allowed for Petty Supervision, contingencies and Unforeseen items.

Types of Estimates

ABSTRACT OF ESTIMATE FORM

Item No.	Description/ Particulars	Quantity	Unit	Rate	Per (Unit)	Amount

The detailed estimate should accompanied with

- I) Report
- ii) Specification
- iii) Drawings (plans, elevation, sections) iv)
- Design charts and calculations
- v) Standard schedule of rates.

1.4.5 FACTORS TO BE CONSIDERED WHILE PREPARING DETAILED ESTIMATE

i) Quantity and transportation of materials:

For bigger project, the requirement of materials is more. such bulk volume of materials will be purchased and transported definitely at cheaper rate.

ii) Location of site:

The site of work is selected, such that it should reduce damage or in transit during loading, unloading, stocking of materials.

iii) Local labor charges:

The skill, suitability and wages of local labors are considered while preparing the detailed estimate.

1.4.6 DATA

The process of working out the cost or rate per unit of each item is called as Data. In preparation of Data, the rates of materials and labor are obtained from current standard scheduled of rates and while the quantities of materials and labor required for one unit of item are taken from Standard Data Book.

1.4.7 FIXING OF RATE PER UNIT OF AN ITEM

The rate per unit of an item includes the following:

1) Quantity of materials & cost:

The requirement of materials is taken strictly in accordance with standard data book(S.D.B). The cost of these includes first cost, freight, insurance and transportation charges.

2) Cost of labour:

The exact number of labourers required for unit of work and the multiplied by the wages/ day to get of labour for unit item work.

3) Cost of equipment (T&P):

Some works need special type of equipment, tools and plant. In such case, an amount of 1 to 2% of estimated cost is provided.

4) Overhead charges:

To meet expenses of office rent, depreciation of equipment salaries of staff postage, lighting an amount of 4% of estimate cost is allocated.

1.4.8 METHODS OF PREPARATION OF APPROXIMATE ESTIMATE

Preliminary or approximate estimate is required for studies of various aspects of work of project and for its administrative approval. It can decide, in case of commercial projects, whether the net income earned justifies the amount invested or not. The approximate estimate is prepared from the practical knowledge and cost of similar works. The estimate is accompanied by a report duely explaining necessity and utility of the project and with a site or layout plan. A percentage 5 to 10% is allowed for contingencies. The following are the methods used for preparation of approximate estimates.

a) Plinth area method

b) Cubical contents methods

c) Unit base method.

1.4.9 Plinth area method

The cost of construction is determined by multiplying plinth area with plinth area rate. The area is obtained by multiplying length and breadth (outer dimensions of building). In fixing the plinth area rate, careful observation and necessary enquiries are made in respect of quality and quantity aspect of materials and labour, type of foundation, height of building, roof, wood work, fixtures, number of storey's etc., As per IS 3861-1966, the following areas

include while calculating the plinth area of building

Types of Estimates

- a) Area of walls at floor level.
- b) Internal shafts of sanitary installations not exceeding 2.0m², lifts, air-conditioning ducts etc.,
- c) Area of barsati at terrace level: Barsati means any covered space open on one side constructed on one side constructed on terraced roof which is used as shelter during rainy season.

Centre Line Method

S.No.	Particulars of Items	No.	L	B	H	Q	Explanation
1.	Earth Work excavation for foundation 53 	1	19.2	0.9	1.4	24.192	m ³ L=2(5.3+4.3)=19.2
2.	C.C.(1:4:8) bed for foundation	1	19.2	0.9	0.3	5.184	m ³
3.	R.R.Masonry in CM (1:6) for						
	a) Footings	1	19.2	0.6	0.5	5.76	
	b) Basement	1	19.2	0.45	0.6	5.184	
					Total	10.944	m ³
4.	Brick masonry with CM(1:6) for super structure	1	19.2	0.3	0.3	17.28	m ³

d) Porches of non cantilever type.

Areas which are not to include

- a) Area of lofts.
- b) Unenclosed balconies.
- c) Architectural bands, cornices etc.,
- d) Domes, towers projecting above terrace level.
- e) Box louvers and vertical sunbreakers.

1.4.10 Cubical Contents Method

This method is generally used for multistoreyed buildings. It is more accurate than the other two methods viz., plinth area method and unit base method. The cost of a structure is calculated approximately as the total cubical contents (Volume of buildings) multiplied by Local Cubic Rate. The volume of building is obtained by Length x breadth x depth or height. The length and breadth are measured out to out of walls excluding the plinth offset. The cost of string course, cornice, corbelling etc., is neglected. The cost of building = volume of buildings x rate/ unit volume.

1.5 PROBLEMS

1.5.1 Estimation of different foundations, steps and boundary walls.

Example : 1 From the Drawing given below determine (a) Earth work excavation

(b) CC (1:5:10) Bed (c) R.R.Masonry in C.M. (1:6) (d) Brick Work in C.M.(1:6).

Single Roomed Building (Load Bearing type structure)

1. From the Drawing given below determine (a) Earth work excavation

(b) CC (1:5:10) Bed (c) R.R.Masonry in C.M. (1:6) (d) Brick Work in

C.M.(1:6). by

(a) longwall - short wall method

(b) Centre line Method

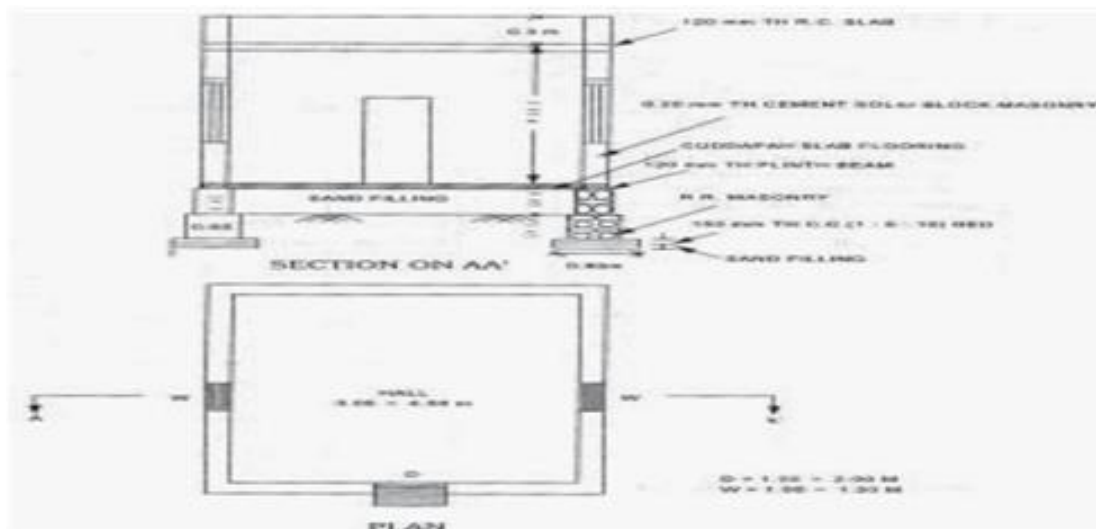

QUESTION BANK PART- A

1. What are the difference between preliminary estimates, detailed estimates, supplementary estimates and revised estimates ?
2. What do you understand by
 - a. Overhead cost
 - b. Analysis of rates
 - c. Contingencies and supervision charges
 - d. Standard measurements book
 - e. Prime cost

- f. Provision of tools and pants and work charged establishment in an estimate.
 - g. Lump-sum items
3. Distinguish clearly between
- a. Revised estimate and supplementary estimate
 - b. Administrative approval and technical sanction
 - c. Plinth area estimate and cube rate estimate
 - d. Contingencies and supervision charges
 - e. Preliminary estimate and detailed estimate
4. Explain the following
- a. Schedule of rates
 - b. Cube rate estimate
 - c. Preliminary estimate
 - d. Provisional items
 - e. Carpet area
 - f. Revised estimate
 - g. Contingencies
 - h. Book value
 - i. Prime cost
 - j. Floor area
5. Discuss the merits and demerits of cubic meter method of approximate estimate.
6. Explain the following terms.
- a. Record drawings
 - b. Standard measurement book
7. What conditions are to be fulfilled before taking up work in hand ?
8. What do you understand by detailed and general specification ?

9. When and where are the following estimates used
 - a. Annual repair estimate
 - b. Revised estimate
 - c. Supplementary estimate
10. What is meant by preliminary estimate?
11. What documents should be supplied along with preliminary estimate.
12. What are different types of Estimates?
13. Which of the methods can give us the exact cost and why?
14. What are the various sub-heads of the report of an estimate of a building?
15. Explain the term provisional items.

PART - B

1. What are different types of Estimates? How do they differ from each other?
2. Prepare a preliminary estimate of a four storied office building having total carpet area of 2000.sq.m for obtaining the administrative approval of the government, given the following data . It may be assumed that 40% of the built up area will be taken up by corridors, verandah, lavatories, staircase etc. Plinth area rate is Rs. 1325/- per Esq.

Extra for special architectural treatment 0.5% of building cost.

Extra due to deeper foundation at site 1% of building cost.

Extra for water supply and sanitary installation 8% of building cost.

Extra for internal electrical installation 12.5% of building cost.

Extra for other services 5% of building cost.

Contingencies - 2.5%

Supervision charges - 10 %
3. What are the various sub-heads of the report of an estimate of a building ? Support your answer with a brief description.

4. What are the difference between preliminary estimates, detailed estimates, supplementary estimates and revised estimates ?Under what circumstances each one is prepared and what statements and drawings are to be attached with each one them. 5.

Explain what do you understand by

- a. Overhead cost
 - b. Analysis of rates
 - c. Contingencies and supervision charges
 - d. Standard measurements book
 - e. Prime cost
 - f. Provision of tools and pants and work charged establishment in an estimate.
 - g. Lump-sum items
6. Explain the following general items of work involved in the estimation for a building along with the process of calculations.
- a. Earthwork in excavation.
 - b. Earthwork in filling.
 - c. Brick at soling.
 - d. Cement concrete in foundation.
 - e. Masonry work in foundation.
 - f. Damp proof course.
 - g. Masonry work in superstructure.
 - h. 10 cm thick brickwork.
7. Write down unit of measurement, unit rate of payment and mode of measurement
- a. For the following general items of work.
 - b. Bellies.

8. Explain the following estimates
 - a. Detailed estimate
 - b. Repair estimate
 - c. Revised estimate and supplementary estimates due to reduction of cost
 - d. Quantity estimate.

9. Enumerate different methods for estimating building works along with a suitable example.

List and explain any four approximate methods of estimating for buildings.

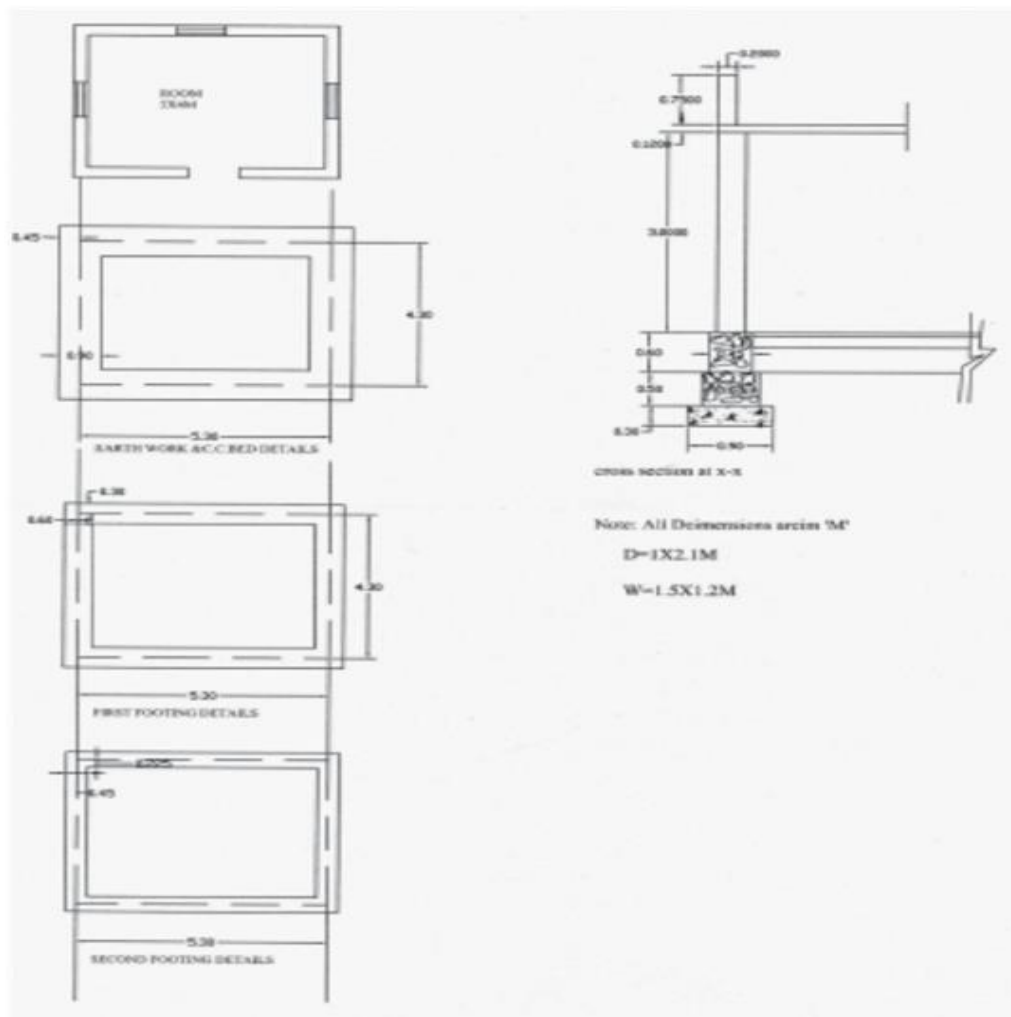

Measurement of Materials and Works Long wall - Short wall Method

ESTIMATION AND VALUATION UNIT II ESTIMATE OF BUILDINGS

TECHNICAL TERMS

1.RETAINING WALL

It is a structure designed and constructed to resist the lateral pressure of soil when there is a desired change in ground elevation that exceeds the angle of repose of the soil.

2.AQUEDUCT

It is a water supply or navigable channel (conduit) constructed to convey water. In modern engineering, the term is used for any system of pipes, ditches, canals, tunnels, and other structures used for this purpose

3. ARCH

It is a structure that spans a space while supporting weight.

4. PITCHED ROOF

It is a roof structure where the roof leans to one side of the house

5.FLAT ROOF

It is a type of covering of a building. In contrast to the sloped form of a roof, a flat roof is horizontal or nearly horizontal.

6.CULVERT

It is device used to channel water. It may be used to allow water to pass underneath a road, railway, or embankment

7.FORMWORK

It is the term given to either temporary or permanent moulds into which concrete or similar materials are poured. In the context of concrete construction, the false work supports the shuttering moulds.

8.LOAD BEARING

It is one in which a wall of a structure bears the weight and force resting upon it, conducting the vertical load from the upper structure to the foundation.

9.HANDRAIL

It is a rail that is designed to be grasped by the hand so as to provide stability or support.

10. TREAD:

It means horizontal upper portion of a step.

UNIT-II

2. 3

11. RISER:

This is the vertical portion of a step. It means the vertical distance between the horizontal surfaces of two consecutive steps.

12. LANDING:

This is a horizontal platform provided at the head of a series of step.

13. NOSING:

This is the outer projecting edge of a tread.

14. FLIGHT:

This is consists of series of steps provided between the landings.

15. FLATSLAB:

A flat slab is reinforced concrete slab supported directly over the columns without beams. Generally used when head room is limited. Such as in cellars and warehouses.

16. PANEL:

Panel is that the part of the slab bounded on each of its form sides by the centre line of columns or center lines of adjacent spans.

17. DROP:

The drop panel is formed by increasing the thickness of slab in vicinity of supporting column.

18. COLUMN HEAD:

The column head or capital located by flaring of the column at the top is primarily intended to increase the punching shear of the slab.

19. BRICK MASONRY:

Masonry structures are built using masonry units and mortar.

20. MASONRY WALL:

Masonry walls are constructed using bricks and mortar.

21. MORTAR:

Masonry units are bonded together using mortars.

UNIT - 2

ESTIMATE OF BUILDINGS

2.1 Load bearing and framed structures

2.1.1 Load bearing (Problems on Plinth Area Method)

Example 2.1: Prepare an approximate estimate of building project with total plinth area of all building is 800 sqm. and from following data.

- i) Plinth area rate Rs. 4500 per sqm
- ii) Cost of water supply @ 7½% of cost of building.
- iii) Cost of Sanitary and Electrical installations each @ 7½% of cost of building.
- iv) Cost of architectural features @ 1% of building cost.
- v) Cost of roads and lawns @ 5% of building cost.
- vi) Cost of P.S. and contingencies @ 4% of building cost. Determine the total cost of building project.

Solution:

Data given:

Plinth area = 800m²

Plinth area rate = Rs. 4500 per Sq.m

Add the cost of the water supply charges @ 7½%	$= \frac{36,00,000 \times 7.5}{100} = 2,70,000 = 00$
Add the Cost of Sanitary and electrical installation @ 15%	$= \frac{36,00,000 \times 15}{100} = 5,40,000 = 00$
Add the cost of architectural features @ 1%	$= \frac{36,00,000 \times 1}{100} = 36,000 = 00$
Add the cost of Roads Lawns @ 5%	$= \frac{36,00,000 \times 5}{100} = 1,80,000 = 00$
Add the Cost of P.S. and contingencies @ 4%	$= \frac{36,00,000 \times 4}{100} = 1,44,000 = 00$
Total	Rs. 47,70,000=00
Assume Add supervision charges 8% on overall cost	$= 47,70,000 \times \frac{8}{100} = 3,81,600 = 00$
Grand Total	Rs. 51,51,600=00

C
o
s
t

of building = 800 x 4500 = Rs. 36,00,000=00

Example 2: The plinth area of an apartment is 500 sqm. Determine the total cost of building from the following data:

- a) Rate of construction = Rs.1230/-per m³.
- b) The height of apartment = 16.25 m
- c) Water Supply, Sanitary and Electrical installations each at 6% of building cost.
- d) Architectural appearance @ 1% of building cost.
- e) Unforeseen item @2% of Building cost.
- f) P.S. and contingencies @4% of building.

Solution :

a) The Cost of building = cubic content x cubic rate
 $= 500 \times 16.25 \times 1230 = \text{Rs. } 99,93,750/-$

b) Provision for water supply, sanitary and Electrical installations water supply and sanitation each @ 6%
 $= \frac{99,93,750 \times 18}{100} = \text{Rs. } 17,98,875/-$

i.e total percent = 3×6 = 18% building cost

c) Architectural appearance @1% = $\frac{99,93,750 \times 1}{100} = \text{Rs. } 99,937/-$

d) Unforeseen items @2% = Rs. 1,99,875/-

e) P.S. and contingencies @4% = Rs. 3,99,750/-

Total = Rs.1,24,92,187/-

Sundries = 7,813/-

Total cost of the building project = Grand Total = Rs.1,25,00,000/-

E

Example 3: The plinth area and plinth area rate of a residential building are 100 sqm and Rs.5000/- respectively. Determine the total cost of building assuming suitable provisions.

Solution :

Cost of building = 100 x 5000 = Rs. 5,00,000

Cost of water supply and

sanitary fittings @15% = $\frac{5,00,000 \times 15}{100} = \text{Rs. } 75,000$

Cost of Electrification @7½% = $\frac{5,00,000 \times 7.5}{100} = \text{Rs. } 37,500$

Cost of Roads & Lawns @5% = $\frac{5,00,000 \times 5}{100} = \text{Rs. } 25,000$

Cost of P.S. & contingencies @4% = $\frac{5,00,000 \times 4}{100} = \text{Rs. } 20,000$

Total Cost = Rs. 6,57,500/-

Example
:Prepare

4

an

approximate Estimate of a proposed building from the following?

Plinth area of the building = 226 sqm.

Cost of the structure = 2500 per sqm.

Water supply and sanitary arrangements = 12½%

$$\begin{aligned} &= \frac{5,65,000 \times 12.5}{100} = \text{Rs. } 70,000 \\ \text{Electrification @7\%} &= \frac{5,65,000 \times 7}{100} = \text{Rs. } 39,550 \\ \text{Fluctuation of rates 5\%} &= \frac{5,65,000 \times 5}{100} = \text{Rs. } 28,250 \\ \text{Petty supervision charges 3\%} &= \frac{5,65,000 \times 3}{100} = \text{Rs. } 16,950 \\ \text{Total Cost Rs.} &= \underline{\underline{7,19,750.00}} \end{aligned}$$

Electrification = 7%

Fluctuation of rates = 5% petty

supervision charges = 3%

Sol: Cost of Building = 226x 2500 = Rs.5,65,000

Water supply & Sanitary arrangements @ 12½ %

2.1.2 Cubical content Method:

Example 5 : Prepare the rough estimate for a proposed commercial complex for a municipal corporation for the following data.

Plinth Area = 500m²/floor Ht of

each storey = 3.5m

No. of storey's = G+2

Cubical content rate = Rs. 1000/m³

Provided for a following as a percentage of structured cost

a) water supply & Sanitary arrangement -8%

b) Electrification -6%

c) Fluctuation of rates - 5%

d) Contractors profit - 10%

e) Petty supervision & contingencies - 3%

Sol :

Cubical content = No. of storey's (Plinth Area x height of each storey) = 3(500x3.5) = 5250m³

Structural cost = Cubical content x cubical content rate = 5250 x 1000 = 52.5 Lakhs

other provisions:-

a) Water supply and sanitation = $52.5 \times 8/100$ = Rs.4.2 Lakhs

b) Electrification = $52.5 \times 6/100$ = Rs.3.15 lakhs

c) fluctuation of rates = $52.5 \times 5/100$ = Rs.2.625

Total = Rs. 9.975 Lakhs

Structural cost = Rs. 52.500 Lakhs

Total = Rs.62.475 Lakhs

d) P.S./& contingencies = $62.475 \times 3/100$ = Rs.1.874 Lakhs

e) Contractors Profit = $62.475 \times 10/100$ = Rs.6.247 Lakhs

Total Cost = Rs.70.596 Lakhs

2.1.3 Unit Base Method

Example 2.6:
Prepare

an approximate estimate or rough cost estimate of a hospital building for 50 beds. The cost of construction altogether for each bed is Rs. 60,000/-. Determine the total cost of hospital building.

Solution:

No. of beds = 50

Cost of construction = Rs. 60,000/-

Total Cost of Hospital building = $50 \times 60,000 = \text{Rs. } 30,00,000/-$

Example 2.7: To prepare the rough cost estimate of a hostel building which accommodate 150 students. The cost of construction including all provisions is Rs. 15,000/- per student. Determine total cost of building.

Solution :

No. of students = 150

Cost of construction including all L.S. provisions = Rs.

15,000/- Total Cost of hostel building = $150 \times 15000 = \text{Rs.}$

22,50,000/- (Rupees twenty two lakhs, fifty thousand only)

Example 2.8: From the given figure below calculate the detailed and abstract estimate for the single roomed building (Load bearing type structure) by

a) long wall & short wall method

b) Centre Line Method

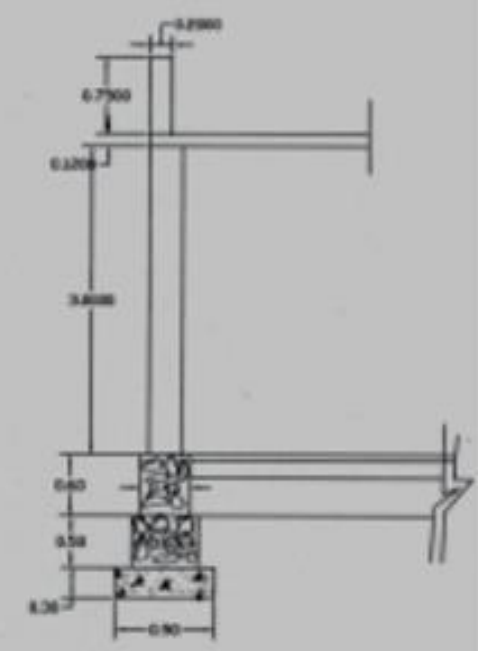
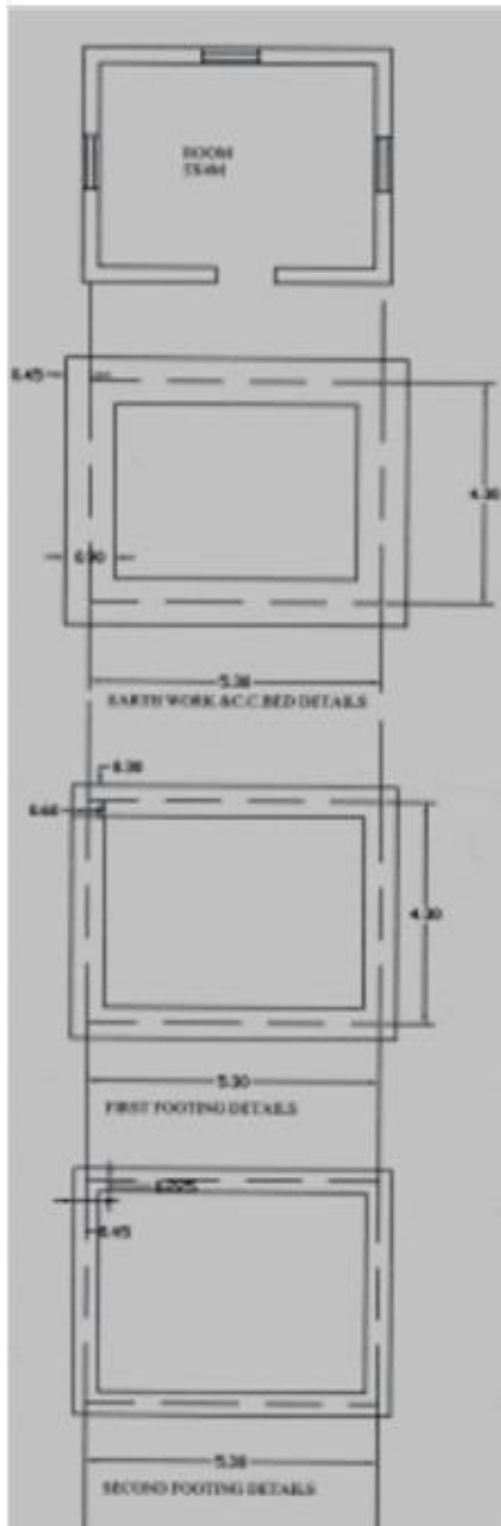

CROSS SECTION AT X-X

Note: All Dimensions are in 'M'

D=1X2.1M

W=1.5X1.2M

a) Long wall - Short Method

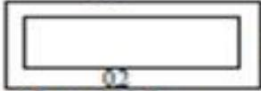
S.No.	Particulars of Items	No.	L	B	H	Q	Explanation
1.	Earth Work excavation for foundation						
	a) Long walls	2	6.2	0.9	1.4	15.264	$L=5.3+0.45+0.45=6.2$ $D=0.3+0.5+0.6=1.4$
	b) Short walls	2	3.4	0.9	1.4	8.568	$L=4.3-0.45-0.45=3.4$
					Total	24.192	m³
2.	C.C.(1:4:8) bed for foundation						
	a) Long walls	2	6.2	0.9	0.3	3.348	
	b) Short walls	2	3.4	0.9	0.3	1.836	
					Total	5.184	m³
3.	R.R.Masonry in CM (1:6) for						
	a) Footings						
	i) Long walls	2	5.9	0.6	0.5	3.54	$L=5.3+0.3+0.3=5.9$
	ii) Short walls	2	3.7	0.6	0.5	2.22	$L=4.3-0.3-0.3=3.7$
					Total	5.76	m³
	b) Basement						
	i) Long walls	2	5.75	0.45	0.6	3.105	$L=5.3+0.225+0.225=5.75$
	ii) Short walls	2	3.85	0.45	0.6	2.079	$L=4.3-0.225-0.225=3.85$
					Total	5.184	m³
	Total R.R. Masonry for footings and Basement						= 5.76+5.184 = 10.94 m³
4.	Brick masonry with CM (1:6) for super structure						
	a) Long Walls	2	5.6	0.30	3.00	10.08	$L=5.3+0.15+0.15=5.6$
	b) Short walls	2	4.0	0.30	3.00	7.20	$L=4.3-0.15-0.15=4.0$
	c) for parapet wall						
	5.6						
							
	0.2						
	a) Long Walls	2	5.6	0.2	0.75	1.68	
	b) Short walls	2	4.4	0.2	0.75	1.32	
					Total	20.28	m³

S.No.	Particulars of Items	No.	L	B	H	Q	Explanation
	Deductions for openings						
	a) Doors	1	1.0	0.3	2.1	0.63	
	b) Windows	3	1.5	0.3	1.2	1.62	
					Total	(-)2.25	m ³
	Net Brick Masonry		= 20.28		- 2.25	=	18.03m ³
5.	R.C.C. (1:2:4) for						
	a) Roof slab	1	5.6	4.6	0.12	3.090	
	b) Lintels over						
	i) Doors	1	1.2	0.3	0.15	0.054	
	ii) Windows	3	1.5	0.3	0.15	0.202	
	c) Beams						
	i) Long beams	2	5.6	0.3	0.3	1.008	
	ii) short beams	2	4.0	0.3	0.3	0.720	
					Total	5.074	m ³
6.	Sandfilling for basement	1	4.85	3.85	0.48	8.96	L=5.0-0.075-0.075=4.85
7	C.C.(1:4:8) for flooring	1	4.85	3.85	0.1	1.86	B=4.0-0.075-0.075=3.85
8	Flooring with Mosaic tiles	1	5.0	4.0	--	20.0	m ²
9	Plastering with CM (1:6) for super structure						
	<u>Inside</u>						
	For walls	1	18.0	--	3.0	54.0	L=2(5.0+4.0)=18.0
	<u>Out side</u>						
	For walls	1	20.4	--	3.87	61.2	L=2(5.6+4.6)=20.4
	Basement outside	1	21.6	--	0.6	12.96	H=3.0+0.12+0.75=3.87 (upto parapet wall)
	Parapet wall						
	a) Inside	1	18.8	--	0.75	14.1	
	b) top	1	19.6	0.2	---	3.92	
	Deductions for openings				Total	146.18	m ²
	Doors	1x2	1.0	--	2.1	4.2	
	Windows	3x2	1.5	--	1.2	10.8	
						15.0	m ²
	Net Plastering		= 146.18		- 15.0	=	131.18 m ²

S.No.	Particulars of Items	No.	L	B	H	Q	Explanation
10	Plastering for Ceiling with CM(1:5)	1	5.0	4.0	--	20.0	m ²
11	White Washing with two coats with Janatha cement						
	Same as quantity of plastering for walls and ceiling					151.18	(=131.18+20=151.18)
12.	Colour washing with two coats						
	Same as quantity of plastering for walls and ceiling					151.18	(=131.18+20)151.18)
13	Supply & Fixing of best country wood for						
	a) Doors	1				1 No.	
	b) Windows	3				3No.	
14	Painting with ready mixed synthetic enamel paints with two coats over primary coat for new wood for						
	a) Doors	2½x1	1.0	---	2.1	4.725	
	b) Windows	2½x3	1.5	---	1.2	12.15	
					Total	16.875	m ²
15	Petty supervision and contingencies at 4% and rounding off						

b) Centre Line Method

S.No.	Particulars of Items	No.	L	B	H	Q	Explanation	
1.	Earth Work excavation for foundation 53  43	1	19.2	0.9	1.4	24192	m ³ $L=2(5.3+4.3)=19.2$	
2.	C.C.(1:4:8) bed for foundation	1	19.2	0.9	0.3	5.184	m ³	
3.	R.R.Masonry in CM (1:6) for							
	a)Footings	1	19.2	0.6	0.5	5.76		
	b)Basement	1	19.2	0.45	0.6	5.184		
					Total	10944		
4.	Brick masonry with CM(1:6)for super structure	1	19.2	0.3	3.0	17.28	m ³	
	For parapet wall	1	20.0	0.2	0.75	3.00		
	Deductions for openings							
	a)Doors	1	1.0	0.3	2.1	0.63		
	b)Windows	3	1.5	0.3	1.2	1.62		
					Total	(-)2.25	m ³	
	Net Brick Masonry =		17.28	+3.0	-2.25	=	18.03	m ³
5.	R.C.C. (1:2:4) for							
	a)roof slab	1	5.6	4.6	0.12	3.090		
	b) Lintels over							
	i) Doors	1	1.2	0.3	0.15	0.054		
	ii) Windows	3	1.5	0.3	0.15	0.202		
	c)beams	1	19.2	1.3	0.3	1.728		
					Total	5.074	m ³	
6.	Sandfilling for basement	1	4.85	3.85	0.48	8.96	$L=5.0-0.075-0.075=4.85$	
7.	C.C.(1:4:8) for flooring	1	4.85	3.85	0.1	1.86	$B=4.0-0.075-0.075=3.85$	

8.	flooring with Mosaic tiles	1	5.0	4.0	--	20.0	
9	Plastering with CM (1:6) for super structure						
	Inside						
	For walls	1	18.0	--	3.0	54.0	
	Out side						
	For walls	1	20.4	--	3.87	61.2	
	Basement outside	1	21.6	--	0.6	12.96	
	Parapet wall						
	a) Inside	1	18.8	--	0.75	14.1	
	b) top	1	19.6	0.2	---	3.92	
	Deductions for openings:				Total	146.18	m²
	Doors	1x2	1.0	--	2.1	4.2	L=5.0-0.075-0.075=4.85
	Windows	3x2	1.5	--	1.2	10.8	B=4.0-0.075-0.075=3.85
						15.0	m²
	Net Plastering =		146.18-15 =			131.18	m²
10	Plastering for Ceiling with CM(1:5)	1	5.0	4.0	--	20.0	m ²
11	White Washing with two coats with Janatha cement						
	Same as quantity of plastering for walls and ceiling					151.18	m ² (131.18+20=151.18)
12.	Colour washing with two coats						
	Same as quantity of plastering for walls and ceiling					151.18	m ²
13	Supply & Fixing of best country wood for						
	a) Doors	1				1 No.	
	b) Windows	3				3No.	

Abstract estimate of single roomed building (load bearing structure)

S.No	Description of item	Quantity	Unit	Rate	Per	Amount
1.	Earth work excaation	24.192	m ³	465	10m ³	1125.00
2.	Cement concrete(1:4:8)	5.184	m ³	4545	1m ³	8009.30
3.	RR.masonry in C.M.(1:5)	10.94	m ³	1391	m ³	15217.50
4.	Sand filling in basement	8.96	m ³	195.20	10m ³	175.00
5.	Brick masonry in country bricks of standard size in CM(1:8)	18.03	m ³	2291	m ³	41306.73
6.	R.C.C. (1:2:4) for lintels, beams etc.	1.984	m ³	6030	m ³	11963.52
7.	R.C.C.(1:2:4) for slabs,	3.09	m ³	6030	m ³	18633.00
8.	Cement concrete (1:5:10) for flooring	1.86	m ³	1452	m ³	2700.72
9.	Supplying and fixing of country wood for doors.	2.1	m ²	1650	m ²	3465.00
10.	Supplying and fixing of country wood for windows and ventilators.	5.4	m ²	2300	m ²	12420.00
11	Plastering to all exposed surfaces of brick work and basement with C.M (1:5)	151.18	m ²	582	10m ²	8798.70
12	White washing with best shell lime	151.18	m ²	116	10m ²	1753.68
13	Flooring with spartek tiles set in C.M (1:3)	20	m ²	4230	10m ²	8460.00
14	Painting with ready mixed enamel paint	16.875	m ²	335	10m ²	565.31
					Total	134593.46
15	Povision for water supply and sanitary arrangements @12.5%					16824.18
16	Provision for electrification @7.5%					10094.50
17	Povision for architectural appearance @2%					2691.86
18	Provision for unforeseen items 2%					2691.86
19	Provision for P.s.and contingencies @4%					5383.73

Grand Total Rs. 172279.65

Example :2.9 From the given figure below calculate the details and abstract estimate for the double roomed building (Load bearing type structure) by a) long wall & short wall method
 (b) Centre Line Method

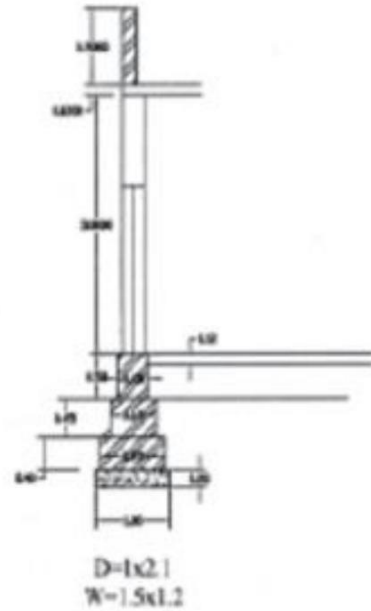
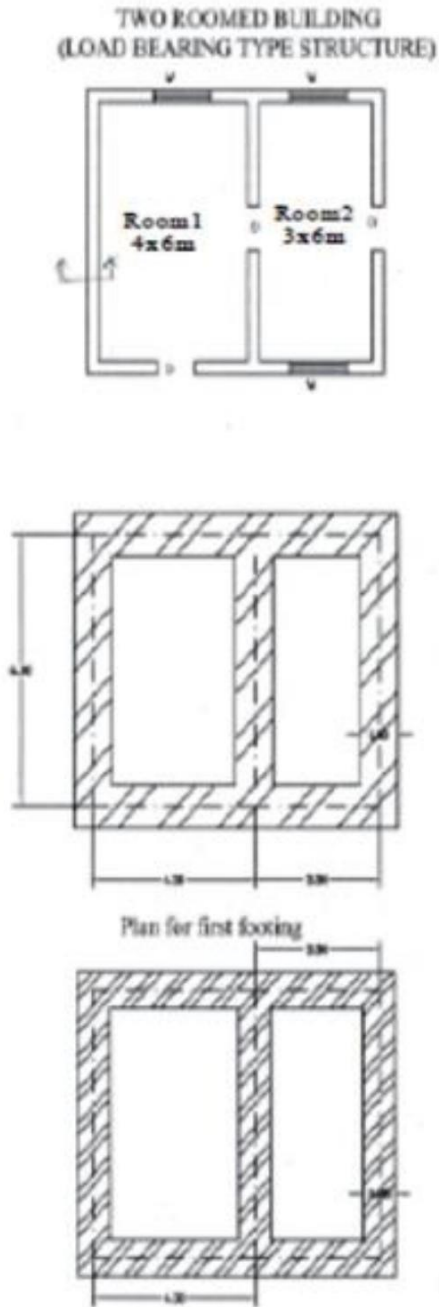

Note: All Dimensions are in 'M'

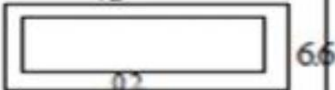
S.No.	Particulars of Items	No	L	B	H	Q	Explanation
1.	Earth Work excavation for foundation						
	a) Long walls	2	8.6	1.0	1.05	18.05	$L=7.6+0.5+0.5=8.6$
	b) Short walls	3	5.3	1.0	11.05	16.70	$L=6.3-0.5-0.5=5.3$
					Total	34.75	m^3
2.	C.C.(1:4:8) bed for foundation						
	a) Long walls	2	8.6	1.0	0.2	3.44	
	b) Short walls	3	5.3	1.0	0.2	3.18	
					Total	6.62	m^3
3.	Brick masonry for footings with CM(1:4)						
	first footing						
	a) Long walls	2	8.45	0.85	0.4	5.746	$L=7.6+0.425+0.425=8.45$
	b) Short walls	3	5.45	0.85	0.4	5.560	$L=6.3-0.425-0.425=5.45$
	2nd footing						
	a) Long walls	2	8.20	0.6	0.45	4.428	$L=7.6+0.3+0.3=8.2$
	b) short walls	3	5.70	0.6	0.45	4.617	$L=6.3-0.3-0.3=5.7$
	ii) for base ment						
	long walls	2	8.00	0.4	0.4	2.560	$L=7.6+0.2+0.0=8.0$
	short walls	3	5.90	0.4	0.4	2.832	$L=6.3-0.2-0.2=5.9$
	iii) for super structure						
	long walls	2	7.90	0.3	3.0	14.22	$L=7.6+0.15+0.15=7.9$
	short walls	3	6.00	0.3	3.0	16.20	$L=6.3-0.15-0.15=6.0$
	iv) Parapet wall						
	79						
							
	a) long walls	2	7.90	0.2	0.70	2.212	
	b) Shot walls	2	6.20	0.2	0.70	1.736	
					Total	60.11	
	Deductions for openings						
	Doors	3	1.0	0.3	2.1	1.89	
	Windows	3	1.5	0.3	1.2	1.62	
	Lintels over doors	3	1.20	0.3	0.10	0.108	
	windows	3	1.70	0.3	0.10	0.153	
	Net B.M.=60.11-3.77=56.34 m^3				Total	3.771	

4	RCC(1:2:4)for						
	a) roof slab	1	7.9	6.6	0.12	6.256	
	b) for lintles over doors	3	1.2	0.3	0.1	0.108	
	Windows	3	1.7	0.3	0.1	0.153	
	c) beams	1	33.8	0.3	0.3	3.042	
					Total	9.298	m ³
5.	Plastering for walls	1	20.0	--	3.0	60.00	L=2(4.0+6.0)=20
	a) Inside room1	1	18.0	---	3.0	54.00	
	room2	1	29.0	---	3.0	87.00	L=2(7.9+6.6)=29
	b) out side	1×2	28.2	---	0.70	39.48	L=2(7.7+6.4)=28.2
	Parapet wall(Sides)	1×1	28.2	0.20	--	5.64	
					Total	246.12	m ²
	Deductions						
	a) doors	3×2	1.0	---	2.10	12.6	
	b) windows	3×2	1.5		1.20	10.8	
					Total	23.4	m ²
	Net Plastering				= 246.12 - 23.4 =	222.72	m ²
6.	flooring with cuddapah slab in cm (1:3)						
	Room1	1	4.0	6.0	---	24	
	Room2	1	3.0	6.0	---	18	
					Total	42	m ²
7	Plastering for ceiling = same as flooring					42	
8	White washing = same as plastering for walls & Ceiling					= 222.72 + 42 = 264.72	m ²
9	Colour washing with two coats						
	Same as quantity of plastering for walls and ceiling					264.72	m ²
10	Supply & Fixing of best country wood for						
	a) Doors	3				3Nos.	
	b) Windows	3				3 Nos	
11	Painting with ready mixed synthetic enamel paints two coats over primary coat for new wood for						
	a) Doors	2 1/2 × 3	1.0	--		14.175	
	b) Windows	2 1/2 × 3	1.5	--		11.13	
						25.305	m ²
12	2% unforeseen items						
13	4% P.S & contingencies and round off.						

b) Centre Line Method

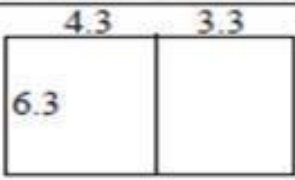
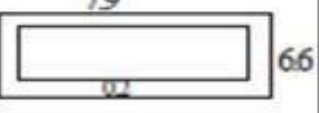
S.No.	Particulars of Items	No.	L	B	H	Q	Explanation
	 <p>4.3 3.3</p> <p>6.3</p>						
	<p>Total centre line length $= (4.3+3.3) \times 2 + 6.3 \times 3 = 34.1 \text{ m}$</p>						
1.	Earth work excavation	1	33.1	1.0	1.05	34.75	$L=34.1-2 \times 1/2=33.1$
2.	C.C.(1:4:8) bed for foundation	1	33.1	1.0	0.20	6.62	m^3
3.	Brick masonry with CM(1:4)						
	a) for foundation						
	i) 1st footing	1	33.25	0.85	0.40	11.30	$L=34.1-0.85=33.25$
	ii) 2nd footing	1	33.50	0.60	0.45	9.045	$L=34.1-0.6 \times 2/2$
	b) for basement	1	33.7	0.40	0.40	5.392	$L=34.1-0.4 \times 2/2$
	c) for super structure	1	33.80	0.30	3.0	30.42	$L=34.1-0.3 \times 2/2$
	d) for parapet wall			77			
	 <p>7.7</p> <p>6.6</p> <p>0.2</p>						
	<p>Total centre line length $= 2(7.7+6.4)=28.2$</p>	1	28.2	0.2	0.70	3.948	
					Total	60.10	m^3
	Deductions for						
	Openings Doors	3	1.0	0.3	2.1	1.89	
	windows	3	1.5	0.3	1.2	1.62	
	Lintels Doors	3	1.2	0.3	0.1	0.108	
	Windows	3	1.7	0.3	0.1	1.153	
					Total	3.771	m^3
	<p>Net B.M. = $60.10 - 3.771 = 56.34 \text{ m}^3$</p>						
4.	Quantity of R.C.C. Roof, Plastering for walls and ceiling and flooring. White washing is same as Long wall & Short wall method.						

Example 2.10 From the given figure below calculate the details and abstract estimate for this single storied residential building with no of rooms (Load bearing type structure) by Centre Line Method

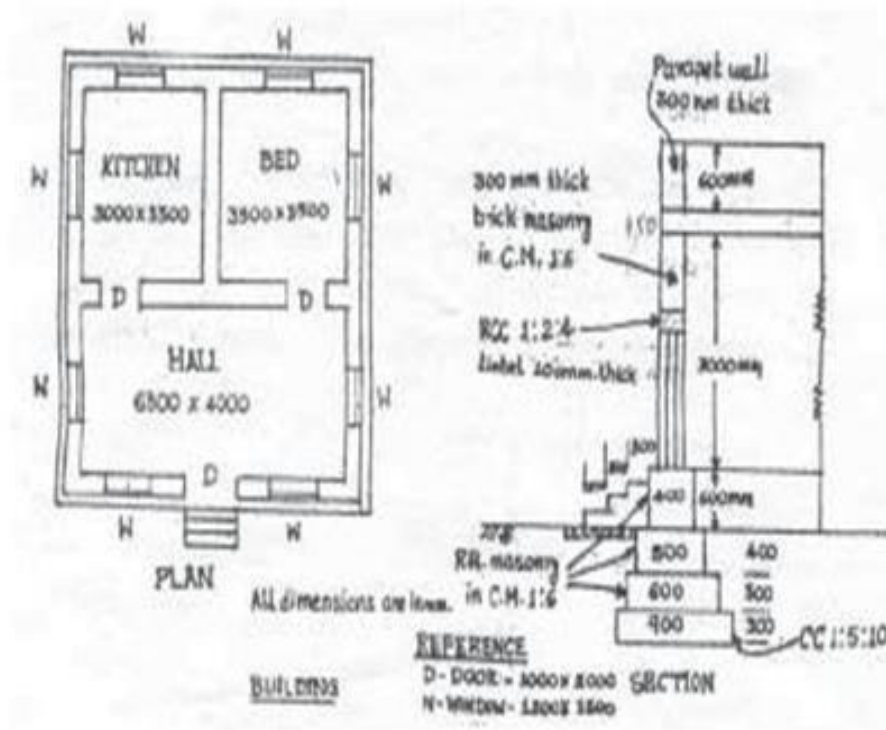

2. 22

Centre line diagram

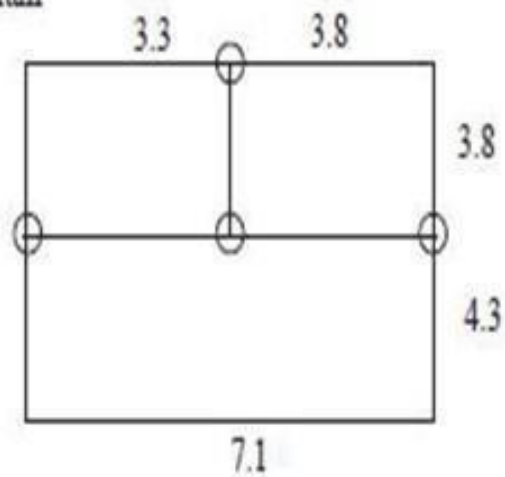

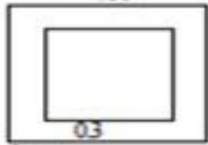
S.No.	Particulars of Items	No	L	B	H	Q	Explanation
1.	Earth work Excavation	1	39.5	0.9	1.0	35.55	$41.3-4 \times 0.9/2=39.5$
2.	C.C. bed(1:5:10)	1	39.5	0.9	0.3	10.665	m^3
3.	R.R. Masonary in CM 1:6						
	1st Footing	1	40.1	0.6	0.3	7.218	$41.3-4 \times 0.6/2=40.1$
	IInd Footing	1	40.3	0.5	0.4	8.06	$41.3-4 \times 0.5/2=40.3$
	Basement	1	40.5	0.4	0.6	9.72	$41.3-4 \times 0.4/2=40.5$
					Total	25.00	m^3
4.	Damp proof course over basement alround the building with CC (1:2:4)	1	40.5	0.6	---	16.2	m^2
	Deduct for Door sills	3	1.0	0.3		- 0.9	m^2
	Net Quantity = $16.2-0.9=15.3$ sq.m				---		
5.	First class brick work in wall in						
	a) superstructure with CM 1:6	1	40.7	0.3	3.0	36.63	$L = 41.3-4 \times 0.3/2$
	b) Parapet wall	1	30.4	0.3	0.6	5.472	$L=2(7.1+8.1)$
			7.1		Total	42.102	m^3
		8.4			8.1		
							
	<u>Deductions:</u>						
	Doors	3	1.0	0.3	2.0	1.80	
	Windows	8	1.2	0.3	1.5	4.32	
	Lintel opening over						
	Doors	3	1.2	0.3	0.1	0.108	Asue 100mm
	Windows	8	1.4	0.3	0.1	0.336	projection on either
					Total	6.564	side
	Net Quantity of BM = $42.102-6.564=35.538$ m^3						
6.	Plastering with 12mmth in CM 1:5	1x2	40.1	---	3.0	240.6	$L=41.3-4 \times 0.3=40.1$
	Deductions for openings						

S.No.	Particulars of Items	No.	L	B	H	Q	Explanation
	Doors	3x2	1.0	---	2.0	12.0	
	windows	8x2	1.2	---	1.5	28.8	
					Total	40.8	m ²
	Plastering for parapet wall (sides)	1x2	30.4	---	0.6	36.48	
	Top	1	30.4	0.3	---	9.12	
					Total	45.60	m ²
	Net Plastering = 240.6 - 40.8 + 45.6 = 245.4 m ²						
7.	Flooring with 25mmth CC(1:2:4)						
	Kitchen	1	3.0	3.5	--	10.5	
	Bed	1	3.5	3.5	--	12.25	
	Hall	1	6.8	4.0	--	27.20	
	Sills of Doors	3	1.0	0.3	--	0.90	
8.	Ceiling = Same as Flooring				Total	50.85	m ²
						50.85	m ²
9.	white washing = Same as Plastering for walls and ceiling 245.4 + 50.85 = 296.25 m ²						
10.	RCC(1:2:4) for						
	a) Slab	1	7.40	8.40	1.5	9.324	
	b) lintels over Doors	3	1.2	0.3	0.1	0.108	
	Windows	8	1.4	0.3	0.1	0.336	
	c) beams	1	40.7	0.3	0.3	3.663	
					Total	13.431	m ³
11	Supply & Fixing of best country wood for						
	a) Doors	3				3Nos.	
	b) Windows	8				8 Nos	
12	Painting with ready mixed synthetic enamel paints two coats over primary coat for new wood for						
	a) Doors	2 1/2 x 3	1.0	--	2.0	13.50	
	b) Windows	2 1/2 x 8	1.2	--	1.5	32.40	
						45.90	m ²
13	2% unforeseen items						
14	4% P.S& contingencies and round off.						

2.1.4 FRAMED STRUCTURES

Example 2.11 From the given figure below calculate the details and abstract estimate for the single storied residential building with no. of rooms (**Framed Structured** type) by Centre Line Method

S.No.	Particulars of Items	No.	L	B	H	Q	Explanation
	Doors	3x2	1.0	---	2.0	12.0	
	windows	8x2	1.2	---	1.5	28.8	
					Total	40.8	m ²
	Plastering for parapet wall (sides)	1x2	30.4	---	0.6	36.48	
	Top	1	30.4	0.3	---	9.12	
					Total	45.60	m ²
	Net Plastring = $240.6 - 40.8 + 45.6 = 245.4 \text{ m}^2$						
6.	Flooring with 25mm th CC(1:2:4)						
	Kitchen	1	3.0	3.5	--	10.5	
	Bed	1	3.5	3.5	--	12.25	
	Hall	1	6.8	4.0	--	27.20	
	Sills of Doors	3	1.0	0.3	--	0.90	
7.	Ceiling = Same as Flooring				Total	50.85	m ²
						50.85	
8.	white Washing = Same as Plastering for walls and ceiling $245.4 + 50.85 = 296.25 \text{ m}^2$						
9.	RCC(1:2:4) for						
	a) Slab	1	7.40	8.40	1.5	9.324	
	b) lintels over Doors	3	1.2	0.3	0.1	0.108	
	Windows	8	1.4	0.3	0.1	0.336	
	c) beams	1	40.7	0.3	0.3	3.663	
					Total	13.431	m ³
10	Supply & Fixing of best country wood for						
	a) Doors	3				3Nos.	
	b) Windows	8				8 Nos	
11	Painting with ready mixed synthetic enamel paints two coats over primary coat for new wood for						
	a) Doors	2½x3	1.0	--	2.0	13.50	
	b) Windows	2½x8	1.2	--	1.5	32.40	
						45.90	m ²
12	2% unforeseen items						
13	4% P.S & contingencies and round off						

Example 2.12 From the given figure below calculate the details and abstract estimate for the two storied residential building with no. of rooms (Framed Structured type) by Centre Line



Ground Floor Plan

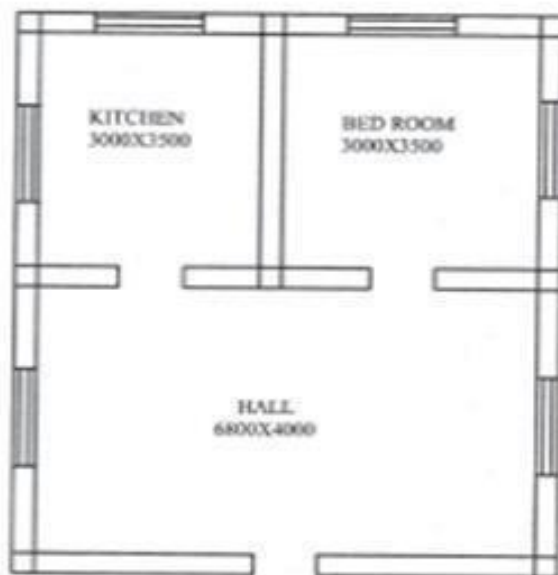

First Floor Plan

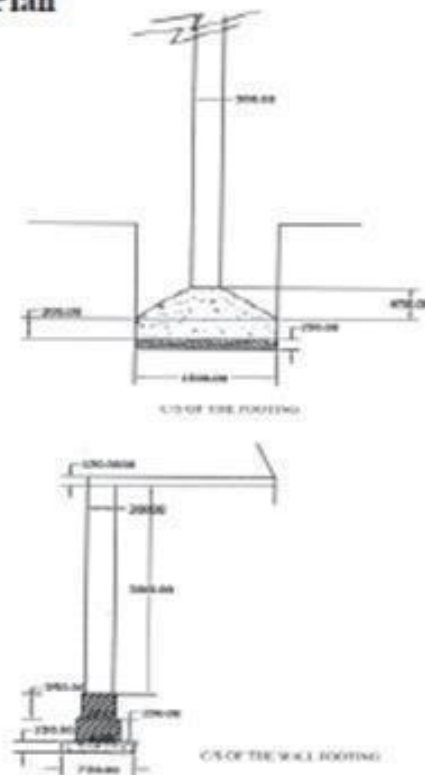

Method

S.No.	Particulars of Items	No.	L	B	H	Q	Explanation
	The quantities of various items of the building for the Ground floor is same as previous problem. Here the quantities of various items of the building for the First floor is mentioned here.						
	First Floor						
1	R.C.C. (1:1.5:3) for						
	a) Columns	8	0.3	0.30	3.0	2.16	
	b) Slabs	1	7.40	8.4	0.15	9.324	
	c) beams	1	40.7	0.3	0.3	3.663	
	d) lintels over doors	1	1.2	0.3	0.1	0.036	
	windows	6	1.4	0.3	0.1	0.252	
					Total	<u>15.435</u>	m ³
2.	B.M with CM(1:8) in the first floor	1	28.6	0.3	3.0	25.74	
	Parapet wall	1	30.4	0.3	0.6	5.47	
	Deductions for openings						
	Doors	1	1.0	0.3	2.0	-0.6	
	Windows	6	1.2	0.3	1.5	-3.24	
	Net BM =	25.74	+5.47	-0.6	-3.24	=	<u>27.372</u> m ³
3.	Plastering with CM(1:4) for walls	1x2	30.4	--	3.0	182.4	
	for parapet wall sides	1x2	30.4	--	0.6	36.48	
	Parapet wall Top	1	30.4	0.3	--	9.12	
	Deductions						
	Doors	1	1.0	---	2.0	-2.0	
	Windows	6	1.2	--	1.5	-10.8	
					Total	<u>215.2</u>	m ²
4.	Flooring with CM(1:3)	1	6.8	7.8	---	53.04	m ²
5.	Plastering for ceiling with CM(1:3) = Same as Flooring					53.04	m ²
6.	White washing or colour washing = same as ceiling & BM						
	= 53.04 + 215.2 =	268.24					m ²
7.	The estimation of a staircase is mentioned separately in the next problem						

2.1.5 PITCHED ROOF

Example 2.13 Estimate the Quantities of the pictured roof shown in figure

- a) Size of common rafter = 80x40mm
- b) Size of ridge piece = 120x 200mm
- c) Size of eaves board = 20 x 300mm

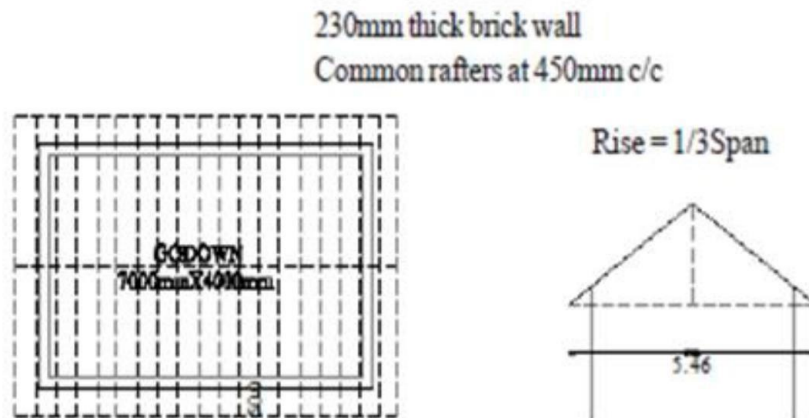

a) Length of Common rafter = $\left(\frac{\text{length}}{2}\right)^2 + \left(\frac{\text{Span}}{3}\right)^2 = \sqrt{2.73^2 + \left(\frac{5.46}{3}\right)^2}$
= 3.28m

b) Length of ridge piece = 7.0+0.23x2 +0.5x2 = 8.46 m

c) Length of Eaves board = 2(8.46+5.46) = 27.84m

S.No	Description	No	L	B	H	Qty	Remarks
1	Ridge piece	1	8.46	0.12	0.20	0.20	Unit of eaves Board in m ²
2	Eaves Board	1	27.84	—	0.30	8.35	
3	Common rafters	40	3.28	0.08	0.04	0.42	

2.1.6 STAIRCASE

Example 2.14 Calculate the quantities of items of the stair case of the figure shown in below.

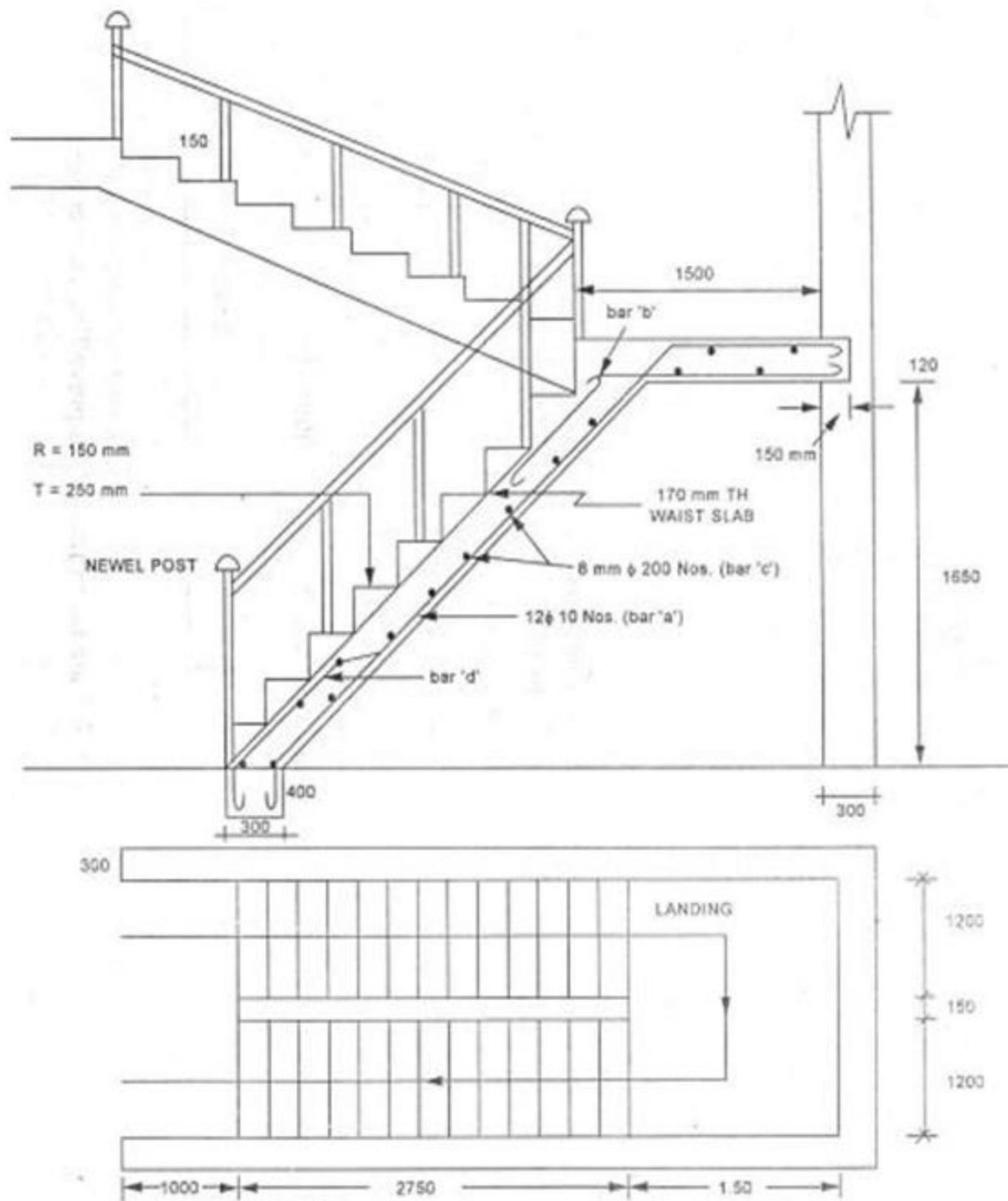

Fig. 4.12

R.C.C. Stair Case

S.No.	Particulars of Items	No.	L	B	H	Q	Explanation
1	R.C.C. (1:2:4) excluding steel and its fabrication but including centering and shuttering and binding wire.						
	a) Toe wall	1x1	3.15	0.3	0.4	0.38	m^3 $L=(1.2+0.15+1.2+2 \times 0.3)$
	b) Waist slab for I and II flights	1x2	3.21	1.2	0.17	1.31	$L = \sqrt{2.75^2 + 1.65^2} = 3.21m$
	c) Landing Middle and first floor	1x2	2.85	1.65	0.17	1.60	$L=(1.2+0.15+1.2+2 \times 0.15)$
					Total	3.29	m^3
2.	1st class brick work in C.M (1:4) for steps	2x11	1.2	$\frac{1}{2} \times (0.25+1.5)$		0.495	
3.	20mm. thick cement plastering (1:5) for steps finished neat						
	a) Treads & Rises	2x11	1.2	$\times (0.25+0.15)$		10.56	
	b) ends of steps	2x11		$\frac{1}{2} \times (0.25+1.5)$		0.41	
					Total	10.97	m^2
4.	2.5cm No sing in steps	2x12	1.2	--	--	28.8	RM
5.	2.5cm C.C. flooring finished neat cement floating in middle and first floor landing.	1x2	2.55	1.2	--	6.12	m^2
6.	Supplying and fixing of best teak wood hand rail finished smooth	1x1	6.67	--	--	6.67	RM
7.	supply and fixing of best teak wood newel posts & finished smooth	1x2	1.0	0.1	0.1	0.02	m^3
8.	Cap of Newel post	1x2	---	--	---	2Nos.	

2.1.7 COMPOUND WALL

Example 2.15 From the given figure below calculate the details estimate for the Compound Wall

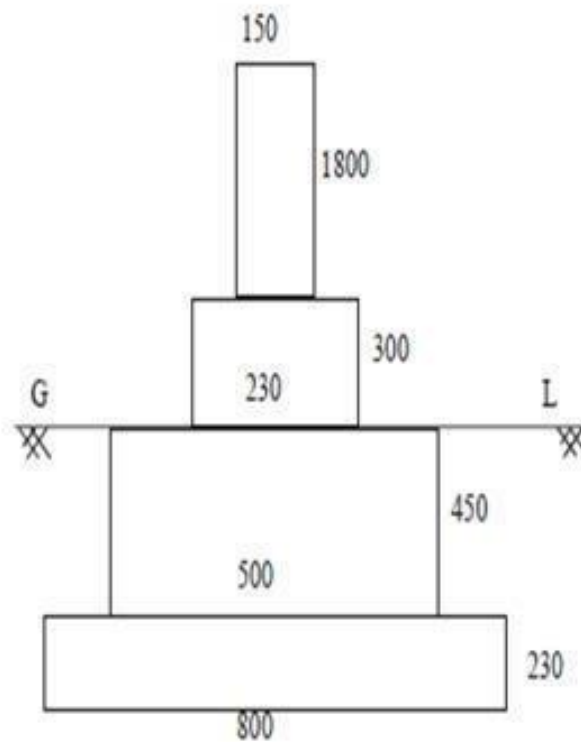
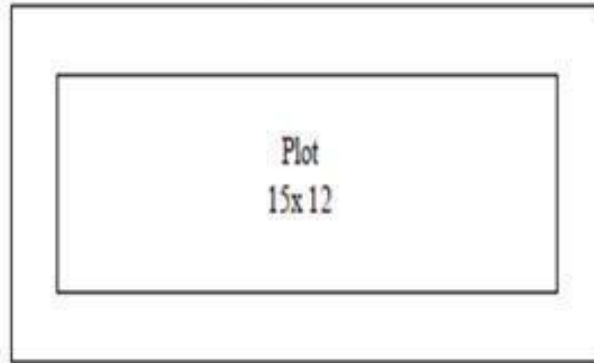

Note: 1) Brick Pillars of size 230x 230 size are built every 3 meters 2) The expansion joints are provided for every 6m length

Cross Section of the compound wall

Example 2.16 Estimation of basement steps (one way)

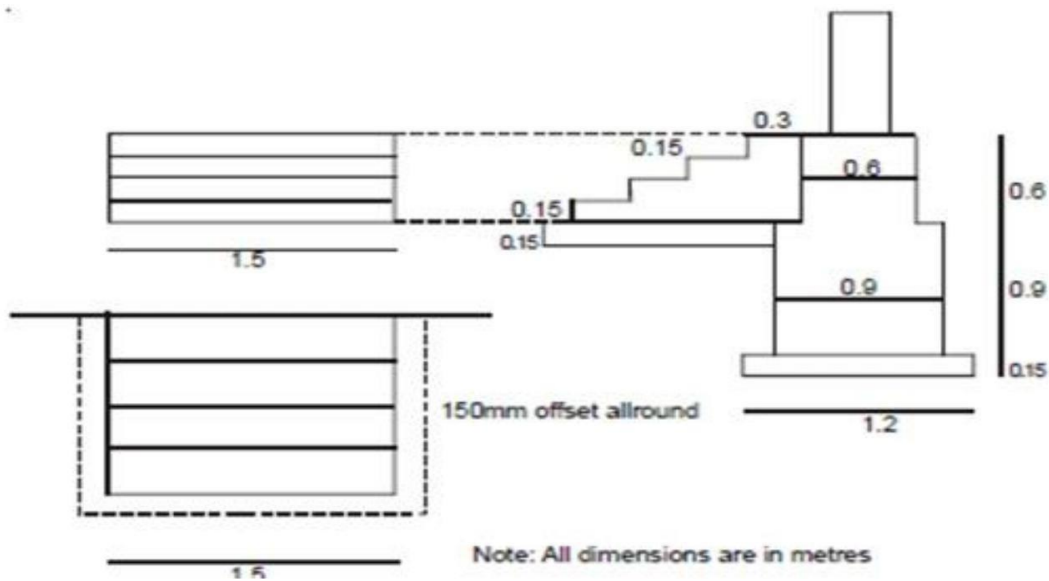

S.No.	Particulars of Items	No.	L	B	H	Q	Explanation
1	Earth work excavation for foundation	1	1.8	1.35	0.15	0.360	m ³
2.	C.C.(1:4:8)bed for foundation	1	1.8	1.35	0.15	0.360	m ³
3.	Ist class BM in CM(1:4)						
	a) 1st step	1	1.5	1.20	0.15	0.27	
	b) 2nd Step	1	1.5	0.90	0.15	0.27	
	c) 3rd Step	1	1.5	0.60	0.15	0.13	
	d) 4th step	1	1.5	0.30	0.15	0.06	
					Total	0.73	m ³
4.	Plastering with CM(1:3)						
	a) Threads	4	1.5	---	---	1.8	
	b) Risers	4	1.5	---	0.15	0.9	
	c) ends						
	a) 1st step	2	1.2	---	0.15	0.36	
	b) 2nd Step	2	0.9	---	0.15	0.27	
	c) 3rd Step	2	0.6	---	0.15	0.18	
	d) 4th Step	2	0.3	---	0.15	0.09	
					Total	3.60	m ²
5.	white washing /colour washing = Same as item (4)					3.60	m ²

UNIT - III

SPECIFICATION AND RATE ANALYSIS

3.1 GENERAL OR BRIEF SPECIFICATION:

This gives the nature and class of the work and materials in general terms, to be used in the various parts of work, from the foundation to the superstructure. It is a short description of different parts of work specifying materials, proportions, qualities, etc., General specifications give general idea of the whole work or structure and are useful for preparing for estimate

3.2 DETAILED SPECIFICATIONS

3.2.1 DETAILED SPECIFICATIONS OF EXCAVATIONS, FILLING AND BACKFILLING

Scope of Work

The scope for work covered under this specifications pertain to excavation of foundations, trenches, pits and over areas, in all sorts of soil, soft and hard rock, correct to dimensions given in the drawing including shoring, protections of existing underground utilities of any, such as water lines, electric cables etc. dewatering and shoring if necessary, stacking the useful materials as directed within the lead specified, refilling around the foundation and into the plinth with selected useful excavated earth and disposing off the surplus earth / materials within specified lead and finishing the surface to proper levels, slopes and camber etc. all complete.

Site Clearance:

Before the earth work is started the area coming under cutting and filling shall be cleared of all obstruction, loose stones, shrubs, rank vegetation, grass, bushes and rubbish removed up to a distance of 150 metres outside the periphery of the area under clearance. This work is deemed to be included in the earthwork item rate and no separate payment will be admissible.

Roots and Vegetation clearance: The roots of trees if any shall be removed to a minimum depth of 60 cm below ground level or a minimum of 30 cm below formation level whichever is lower and the hollows filled up with earth leveled and rammed. This work is deemed to be included in the earthwork items and no separate payment will be admissible for the work. Any material obtained from the site will be the property of the Government of India and the useful materials as decided by the Engineer-in-charge will be conveyed and properly stacked as directed within the lead specified.

Setting out and making profiles:

Masonry or concrete pillars will be erected at suitable points in the area to serve as benchmarks for the execution of the work. These benchmarks shall be connected with G.T.S. or any other permanent benchmark approved by the Engineer-in-charge. Necessary profiles with pegs, bamboos and strings or Burjis shall be made to show the correct formation levels before the work is started. The contractor shall supply labour and materials for setting out and making profiles and Burjis for the work at his own cost and the same shall be maintained during the excavation work. The Department will show grid co-ordinate or other reference points. It shall be the responsibility of the contractor to set out center lines correctly with reference to the drawings and install substantial reference marks. Checking of such alignment by the Department will not absolve the contractor from his responsibility to execute the work strictly in accordance with the drawings.

Excavation:

The contractor shall notify the Engineer-in-charge before starting excavation and before the ground is disturbed, to enable him to take existing level for the purpose of measurements. The ground levels shall be taken at 5 to 15 metres intervals in uniformly sloping ground and at closer distance where local mounds, pits, or undulations are met with, as directed by the Engineer-in-charge. The ground levels shall be recorded in field books and plotted on plans, which shall be signed by the Contractor and the Engineer-in-charge, before the earthwork is actually started. The labour required for taking levels, shall be supplied by the Contractor at his own cost. The Contractor shall perform excavation in all types of soils, murrum, soft and hard rock, boulders etc. in foundation, over areas and in trenches to widths, lines, levels, grades and curves as shown in the drawing or lesser widths, lines, levels, grades and levels as directed by the Engineer-in-charge and per items in the schedule of quantities.

The item in the schedule of quantities shall specify the excavation in trenches or over areas. For this purpose, the excavation for any depth in trenches for foundation not exceeding 1.5m in width or 10sqm. on plan shall be described as excavation in foundation trenches. Excavation exceeding 1.5m in width as well as 10sqm. on plan (excluding trenches for pipes, cables etc.) and exceeding 30cm in depth shall be described as excavation over areas. Excavation exceeding 1.5m in width as well as 10sqm. on plan but not exceeding 30cm. in depth shall be described as surface Excavation.

Classification of Earth work:

The earthwork shall be classified under the following main categories and measured separately for each category. All types of soil, murrum, boulders, Soft rock, Hard rock.

All types of Soils, Murrum, Boulders:

This includes earth, murrum, top deposits of agricultural soil, reclaimed soil, clay, sand or any combination thereof ad soft and hard murrum, shingle etc. which is loose enough to be removed with spadies, shovel and pick axes. Boulders not more than 0.03 cum. in volume found during the course of excavation shall also fall under this classification.

Excavation in Soft Rock:

This shall include all materials which are rock or hard conglomerate, all decomposed weathered rock, highly fissured rock, old masonry, boulders bigger than 0.03 cum, in volume but not bigger than 0.5 cum. and other varieties of soft rock which can be removed only with pick axes, crow bars, wedges and hammers with some difficulty. The mere fact that the contractor resorts to blasting and / or wedging and chiseling of reasons of his own, shall not mean the rock is classifiable as hard rock.

Excavation in Hard Rock :

This includes all rock other than soft rock mentioned in para above 1.5.1 (b) viz. soft rock, occurring in masses, boulders having approximate volume more than 0.5 cum. plain or reinforced cement concrete, which can best be removed by chiseling and wedging where blasting cannot be permitted owing to any restriction at site.

Excavation in Hard Rock by Chiseling and Wedging:

Where blasting is not permitted and if the Engineer-in-charge so desires, the excavation shall be done by chiseling and wedging or any other agreed method.

Note: All the excavated hard rock obtained shall be stacked properly and neatly within the specified lead by the contractor as directed by the Engineer-in-charge

Excavation:

The excavation under all classifications in areas in trenches or in pits shall be carried out systematically. Cutting shall be done from top to bottom and not under pinning or under cutting will be

allowed. The bottom and sides of excavation shall be dressed to proper level, slopes, steps, camber etc. by removing high spots and ramming thoroughly as directed by the Engineer-in-charge. All the excavation shall be carried out strictly to the dimensions given in the drawing. The width shall generally be of the width of mudmat concrete and depth as shown in drawing or as directed by the Engineer-in-charge, according to availability of the desired bearing capacity of soil below. Any excavation if taken below the specified depths and levels, the contractor shall at his own cost fill up such over cut to the specified level with cement concrete 1:4:8 in case of excavation in all types of soils and with cement concrete 1:2:4 in case of excavation soft and hard rock. After the excavation is completed, the contractor shall notify the Engineer-in-charge to that effect and no further work shall be taken up until the Engineer-in-charge has approved the depth and dimensions and also the nature of foundation materials, levels and measurements shall also be recorded prior to taking up any further work.

Shoring:

Unless separately provided for in the schedule of quantities, the quoted rate for excavation shall include excavation of slopes to prevent falling in soil by providing and / or fixing, maintaining and removing of shoring, bracing etc. The contractor would be responsible for the design of shoring for proper retaining of sides of trenches, pits etc. with due consideration to the traffic, superimposed loads etc. shoring shall be of sufficient strength to resist the pressure and ensure safety from slips and to prevent damage to work and property and injury to persons. It shall be removed as directed after items for which it is required are completed should the slips occur, the slipped materials shall be removed and slope dressed to a modified stable slope. Removal of the slipped earth will not be measured for payment.

Dewatering:

Unless specifically provided for as a separate item in the schedule of quantities, rate shall also include bailing or pumping out all water which may accumulate in the excavation during the progress of further works such as mud mat concrete, R.C. footings, shuttering etc. either due to seepage, springs, rain or any other cause and diverting surface flow by bunds or other means. Care shall be taken to ensure that the water discharged sufficiently away from the foundations keep it free from nuisance to other works in the neighborhood.

Disposal of Excavated Materials:

Antiquities:

Any finds of archeological interest such as relics of antiquity, coins, fossils or other articles of value shall be delivered to the Engineer-in-charge and shall be the property of the Government.

Useful Materials:

Any material obtained from the excavation which in the opinion of the Engineer-in-charge is useful, shall be stacked separately in regular stacks as directed by the Engineer-in-charge and shall be the property of the Government. No material excavated from foundation trenches of whatever kind they may be are to be placed even temporarily nearer than about 3m from the outer edge of excavation. Discretion of the Engineer-in-charge in such cases is final. All materials excavated will remain the property of the Department. Rate for excavation includes sorting out of the useful materials and stacking them separately as directed within the specific lead. Material suitable and useful for backfilling or there use shall be stacked in convenient place but not in such a way as to obstruct free movement of materials, workers and vehicles or encroach on the area required for constructional purposes. It shall be used to the extent required to completely backfill the structure to original ground level or other elevation shown on the plan or as directed by the Engineer-in-charge. Materials not useful in anyway shall be disposed off, leveled and compacted as directed by the Engineer-in-charge within a specified lead. The site shall be left clean of all debris and leveled on completion.

Backfilling in sides of Foundations, Plinth, Under Floor etc:

The backfilling shall be done after the concrete or masonry has fully set and shall be done in such a way as not to cause under-thrust on any part of the structure. Where suitable excavated material is to be used for backfilling, it shall be brought from the place where it was temporarily deposited and shall be used in backfilling. The scope of work for backfilling/ filling in foundation, plinth, under floors etc. shall include filling for all the buildings covered under the contract. Surplus earth available from one building, if required, shall be used for backfilling filling for other buildings also within the specified lead mentioned in the item. All timber shoring and form work left in the trenches, pits, floors etc. shall be removed after their necessity ceases and trash of any sort shall be cleared out from the excavation. All the space between foundation masonry or concrete and the sides of excavation shall be backfilled to the original surface with approved materials in layers not exceeding 150mm, in thickness, watered and well consolidated by means of rammers to at least 90% of the consolidation. Areas inaccessible to mechanical equipment such as areas adjacent to walls and columns etc. shall be tamped by hand

rammer or by hand held power rammers to the required density. The backfill shall be uniform in character and free from large lumps, stones, shingle or boulder not larger than 75mm. in any direction, salt, clods, organic or other foreign materials which might rot. The backfilling in plinth and under floor shall be well consolidated by means of mechanical or hand operated rammers as specified to achieve the required density. Test to establish proper consolidation as required will be carried out by the Department at rates specified. Two tests per 50 sqm. will be taken to ascertain the proper consolidation. The cost of tests carried out will be recovered from the contractor's bill.

Filling in Plinth and Under Floors:

After the available suitable excavated materials are exhausted as backfilling, the contractor shall notify the Engineer-in-charge of the fact and levels taken jointly with Engineer-in-charge. The earth, murrum, sand, gravel etc. or such materials suitable for filling proposed to be filled under floors and so mentioned in the item of schedule of quantities shall then be brought to site from approved locations and sources.

Earth Filling:

The earth, soft murrum etc. so brought shall be filled up in layers of 15 cm depth, each layer being well watered and consolidated by approved hand or mechanical tampers or other suitable means to achieve the required density.

Gravel or sand filling:

Gravel if required to be filled under floors, shall be single washed gravel of approved quality and of size varying from 12mm to 20mm. it shall be uniformly blind with approved type of soil and / or sand to obtain full compaction. Gravel shall be filled in specified thickness and shall be well watered and rammed entirely to the satisfaction of the Engineer-in-charge. If sand is required to be filled under floors, it shall be clean, medium grained and free from impurities. The filled in sand shall be kept flooded with water for 24hrs. to ensure maximum consolidation shall be done by the contractor at his own cost. The surface shall then be well dressed and got approved from Engineer-in-charge before any other work is taken over the fill.

Lead and Lift:

Lead: The lead for disposal / deposition of excavated materials shall be as specified in the respective item of work. For the purpose of measurements of lead, the area to be excavated or filled or area on

which excavated material is to be deposited/ disposed off shall be divided in suitable blocks and for each of the block, the distance between center lines shall be taken as the leads which shall be measured by the shortest straight line route on the plan and not the actual route adopted.

Lift: Lift shall be measured from ground level. Excavation up to 1.5m depth below groundlevel and depositing excavated material on the ground shall be included in the item of earthwork for various kinds of soil. Extra lift shall be measured in unit of 1.5m or part thereof. Obvious lift shall only be measured that is lifts inherent in the lead due to ground slope shall not be measured, except for lead up to 250m. All excavation shall be measured in successive stages of 1.5m stating the commencing level. This shall not apply to cases where no lift is involved as in hill side cutting.

Mode of Measurements:

All excavation in areas having depth more than 30cm. pits, trenches etc. shall be measured net. The dimensions for the purpose of payment shall be reckoned on the horizontal area of the excavations for the purpose of payment shall be reckoned on the horizontal area of the excavation at the base for foundations of the walls, columns, footings, rafts or other foundations, multiplied by the mean depth from the surface of ground determined by levels. Excavation for side slopes will not be paid for. Excavation in areas having depths less than 30 cms. shall be measured as surface excavation on square meter basis, mentioning the average depth of excavation.

Reasonable working space beyond concrete dimension required for waterproofing and shuttering where considered necessary in the opinion of Engineer-in-charge will be allowed in execution and considered for payment for underground water tank, sump septic tank etc.

Where direct measurements of rock excavation are not possible, volume of rock can be calculated on the basis of length, breadth, and depth of stacks made at site as mentioned in para 1.5.1 (c). The net volume shall be worked out by reducing it by 40% taking the voids into consideration as 40%. Similarly to arrive at net quantity to be paid in the case of soil, reduction at 20% of corresponding stack / truck measurements shall be made. The rate for excavation shall include carting and disposing and leveling the excavated materials within the specified lead. The rate shall also be inclusive of cost of all tools, plants, explosives, shoring, dewatering at various stages, labour, materials etc. to complete all the operations specified.

The backfilling and consolidation in sides of foundation and in plinth with excavated material will not be paid for separately. The rate quoted for excavation shall be deemed to have been included the cost of stacking of excavated materials, conveying within the specified lead, picking of selected

stacked materials, conveying it to the place of final backfill, compaction to the required proctor density etc. Payment for filling and consolidation inside the trenches, sides of foundations, plinth etc. with selected materials brought by the contractor other than the excavated material, shall be paid for separately as per the rates in schedule of quantities which includes cost of such materials/ excavation, royalty, its conveyance within the specified lead, watering, consolidating, dressing etc. Actual quantity of consolidated filling shall be measured and paid in cubic meters up to two places of decimal. The rate quoted in cum. for items of excavation is deemed to include the necessary additional quantity of excavation involved beyond the plan dimensions of the work which may be necessary to be carried out for carrying out the work in an engineering made, decided upon by the contractor. Therefore no extra payment will be made for any excavation done other than the required quantity as per the plan dimension indicated in the drawings. Measurements for excavation over areas shall be determined by levels or by "Dead men" or both at the discretion of the Engineer-in-charge. If however the Engineer-in-charge decided on measurement by levels, levels of site shall be jointly taken and recorded by the Engineerincharge or his representatives and the contractor, before commencement of the work and after completion of the work and the quantity of work done shall be computed based on these levels. The volume of earth work shall be computed based on "Simpson's formula ' or any other approved method at the discretion of the Engineer-in-charge.

3.2.2 ANTITERMITE TREATMENT:

General:

Pre constructional anti-termite treatment is a process in which soil treatment is applied to a building in early stages of its construction. The purpose of anti-termite treatment is to provide the building with a chemical barrier against the sub-terrain termites. Anti- termite treatment being a specialized job, calls for thorough knowledge of the chemicals, soils, termite to be dealt with and the environmental conditions, in order to give effective treatment and lasting protection to the property undergoing treatment. It is therefore imperative that the works of anti-termite treatment should be got executed through specialized agencies only. The specialized agency should be preferably a member of the Indian pest control Association and shall have sufficient experience of carrying out similar works of magnitude envisaged in this tender.

The pre constructional soil treatment is required to be applied during the construction stages of the sub-structure up to plinth level. The contractor has to be watchful of the various stages of sub-structure works and arrange to carry out the soil treatment in time after proper coordination with Department and other contractors if any, working at site.

Scope:

The scope of pre constructional anti-termite treatment covers the soil treatment with approved chemicals in water emulsion in foundation trenches for columns, plinth beams, plinth filling, at junction of walls and floor, in expansion joints etc. in stages as detailed in this specifications and drawings. Unless otherwise stipulated, the anti-termite treatment will be carried out as per IS 6313 (part II) 1981 and / or as per direction of the Engineer-in-charge.

Site preparation:

In order to ensure uniform distribution of the chemical emulsion and to assist penetration, the following site preparation shall be carried out:

- a) Remove all trees, stumps, logs or roots from the building site.
- b) Remove all concrete form work if left anywhere, leveling pegs, timber offcuts and other building debris from the area to be treated.
- c) If the soil to be treated is sandy or porous, preliminary moistening will be required to fill capillary spaces in soil in order to prevent the loss of emulsion through piping or excessive percolations.
- d) In the event of water logging of foundation, the water shall be pumped out before application of chemical emulsion and it should be applied only when the soil is absorbent.
- e) On clays and other heavy soils where penetration is likely to be slow and on sloping sites, where run-off of the treating solution is likely to occur, the surface of the soil should be scarified to a depth of 75mm at least.
- f) All sub-floor leveling and grading should be completed. All cutting trenches and excavations should be completed with backfilling in place, borrowed fill must be free from organic debris and shall be well compacted. If this is not done supplementary treatments should be made to complete the barrier.

Chemical to be used:

The effectiveness of chemical depends upon the choice of the chemical, the dosage adopted and the thoroughness of application. The chemical solutions or emulsions are required to be dispersed uniformly in the soil and to the required strength so as to form an effective chemical barrier which is lethal and repellent to termites.

Soil treatment:

One of the following chemicals in water emulsion, after approval from the Engineer in charge shall be used uniformly over the area to be treated.

Mode and Rate of Application:

The chemical emulsion as stated above will be applied uniformly by sprayers at the prescribed rates as detailed below in all the stages of the treatment.

Treatment in Foundation Trenches:

In case of normal wall load bearing structures, columns pits, wall trenches and basement, the treatment shall be at 5 litres/sqm. of surface area of the bottom and sides to a height of at least 300mm. After the foundation work, the sides shall be treated at 7.5 litres/sqm. of vertical surface of substructure on each side. After the earth filling is done, treatment shall be done by rodding the earth at 150mm centers close to wall surface and spraying the chemical with the above dose i.e. 7.5 litres/sqm. In case of framed structure, the treatment shall start at a depth of 500mm below ground level. From this depth the backfill around the columns, beams and R.C.C. basement walls shall be treated at 7.5 litres / sqm. of the vertical and at 5 litres / sqm. for the horizontal surface at the bottom in the trenches / pits.

Treatment on Top Surfaces on Plinth Filling:

The top surface of the filled earth within plinth walls shall be treated with chemical emulsion at the rate of 5 litres/sqm. of the surface area before sub-base to floor is laid. If filled earth has been well rammed and the surface does not allow the emulsion to seep through, holes up to 50 to 75mm deep at 150 mm centers both ways shall be made with crow bars on the surface to facilitate saturation of the soil with the emulsion.

Treatment at Junction of Walls and floors:

Special care shall be taken to establish continuity of the vertical chemical barrier on the inner wall surfaces from the finished ground level (or from level where the treatment had stopped) up to the level of the filled earth surface. To achieve this a small channel 30 X 30 mm. shall be made at all the junctions of wall / column with floor (before laying subgrade) and rod holes made in the channel up to the finished ground level at 150mm apart and the iron rod moved backward and forward to break the earth and chemical emulsion poured along the channel at 7.5 litres (or at recommended quantity per sqm. of the vertical wall / column surfaces so as to soak the soil right up to the bottom. The soil shall be tamped back into place after this operation.

Treatment for Expansion Joints:

The soil beneath the expansion joints shall receive special attention when the treatment under 2.5.1 above is in progress. This treatment shall be supplemented by treating through the expansion joint after sub-grade has been laid at the rate of 2 litres per metre length of expansion joint.

Precautions during Treatment:

1. Utmost care shall be taken to see that the chemical barrier is complete and continuous. Each part of the area shall receive the prescribed dosage of chemical emulsion.
2. The treatment should not be carried out when it is raining or when the soil is wet with rain or sub-soil water.
3. Once formed, the treated soil barrier shall not be disturbed. If by chance, treated soil barriers are disturbed, immediate steps shall be taken to restore the continuity and completeness of the barrier system.

Precautions for Health Hazards and Safety Measures:

All the chemicals mentioned above are poisonous and hazardous to health. These chemicals can have an adverse effect upon health when absorbed through the skin, inhaled as vapours or spray mist or swallowed. Persons handling or using these chemicals should be warned of these dangers and advised that absorption through the skin is the most likely source of accidental poisoning. They should be cautioned to observe carefully all the safety precautions particularly when handling these chemicals in the form of concentrates. These chemicals are usually brought to the site in the form of emulsifiable concentrates. The containers should be clearly labeled and should be stored

carefully out of the reach of children and pets animal. They should be kept securely locked. Particular care should be taken to prevent skin contact with concentrates. Prolonged exposure to dilute emulsions should also be avoided. Workers should wear clean clothing and should wash thoroughly with soap and water especially before eating. In the event of severe contamination, clothing should be removed at once and the skin washed with soap and water. If chemicals splash into the eyes they shall be flushed with plenty of water and immediate medical attention should be sought.

The concentrates are oil solutions and present a fire hazard owing to the use of petroleum solvents. Flames should not be allowed during mixing. Care should be taken in the application of chemicals / soil toxicants to see that they are not allowed to contaminate wells or springs and other sources of drinking water.

Guarantee :

The contractor has to furnish the guarantee for 10 (ten) years from the date of completion of work, starting that in case of reappearance of termites within the building area due to defective materials or workmanship or due to any other reasons, the contractor will carry out the necessary post constructional treatment to keep the entire area free from termite, once again, without any extra cost to the Department during the guarantee period.

Mode of measurement:

The payment will be made on the basis of plinth area measurements at ground floor only for all the stages of treatment in sqm. correct to two places of decimals. Rate includes the cost of materials, labour and all tools, plants, sprayers required for complete operation.

3.2.3 HARD CORE / SOLING UNDER FLOORS / FOUNDATIONS:

Scope of work:

The work covered under this specification includes all type of soling work either by bricks or by rubble stones laid under floors / foundations, hand packed, complete as per specification mentioned below and applicable drawings.

Rubble Stone Soling:

The rubble stone shall be of best variety of black trap / granite / basalt or other approved-variety of stone available locally. The stone shall be hard, durable free from defects and of required size and shall be approved by the Engineer-in-charge.

Preparation of Surface:

The bed on which rubble soling is to be laid shall be cleared of all loose materials, leveled, watered and compacted and got approved by the Engineer-in-charge before laying rubble soling. Cable or pipe trenches if shown in the drawing and as required by the Engineer-in-charge shall be got done before the soling is started.

Workmanship:

Over the prepared surface, the stone shall be set as closely as possible and well packed and firmly set. The stones shall be of full height and shall be laid so as to have their bases of the largest area resting on the sub-grade. Soling shall be laid in one layer of 230mm or 150mm depth or specified thickness of soling with a tolerance of 25mm. After packing the stones properly in position, the interstices between them shall be carefully filled with quarry spoils or stone chips of larger size possible to obtain a hard, compact surface. Spreading of loose spoils or stone chips is prohibited. The entire surface shall be examined for any protrusions and the same shall be knocked off by a hammer and all interstices shall be filled with approved murrum. Excess murrum if any over the surfaces shall be removed. Unless otherwise specified, the murrum shall be supplied by the contractor at his own cost from the selected area. The surfaces shall then be watered and consolidated with mechanical or sufficiently heavy wooden tampers and log-rammers as approved by the Engineer. After compaction, the Engineer-in-charge to give the required slope or level and dense sub-base and the surface shall present clean look. Adequate care shall be taken by the contractor while laying and compacting the rubble soling to see that concrete surfaces in contact with soling are not damaged.

Mode of Measurement:

The quoted rate shall be per square metre of the soling of specified thickness. The linear dimension shall be measured up to two places of decimals of a metre and are worked out correct to the two places of decimals of a square metre. Plan areas of soling work actually done limiting to the dimensions as per drawings shall be measured for payment. The rate shall include all the materials

labour, transport etc. and no extra payment shall be made for work done at different levels. The rate shall also include the cost of preparation of surface, all materials and labour, watering, consolidation etc. all complete

UNIT-IV

4.1 REINFORCED CONCRETE AND ALLIED WORKS:

Scope:

This specification covers the general requirements for concrete jobs, using on-site production facilities including requirements in regard to the quantity, handling, storage of ingredients, proportioning, batching, mixing and testing of concrete and also requirements in regard to the quality. This also covers the transportation of concrete from the mixer to the place of final deposit and the placing, consolidation, curing, protecting, repairing and finishing of concrete. After award of the work, if so desired by the contractor, he / they may be allowed by the Engineer-in-charge till the designed mix is obtained, to carry out the reinforced concrete work in foundation and plinth as per equivalent nominal mix against the specified design mix concrete as per IS Codes. However, all other specification for design mix shall govern for nominal mix also and nothing extra shall be paid for use of extra cement on this account whether the cement is supplied by the Department or procured by the contractor.

Cement Concrete (Plain and Reinforced):

The quality of materials and method and control of manufacture and transportation of all concrete work in respect of mix, where reinforced or otherwise, shall conform to the applicable portions of these specifications. The Engineer-in-charge shall have the right to inspect the sources of materials, the layout and operation of procurement and storage of materials, the concrete batching and mixing equipments and the quality control system. Such an inspection shall be arranged by the contractor and the Engineer-in-charge's approval shall be obtained prior to starting the concrete work.

Materials for Standard Concrete:

The ingredients to be used in the manufacture of standard concrete shall consist solely of a standard type Portland cement, clean sand, natural coarse aggregate, clean water, ice and admixtures if specially called for as per drawings or schedule of quantities.

Cement :

Unless otherwise specified or called for by the Engineer-in-charge, cement shall be ordinary Portland cement in 50 kg bags. The use of bulk cement will be permitted only with the approval of the Engineer-in-charge. Changing of brands or type of cement within the

same structure will not be permitted. Ordinary Portland cement (OPC) 43 grade manufactured as per I.S. specifications of reputed brands like ACC / Ultratech / Zuari / Coramendel or any other brands as approved by the Engineer-in-charge from time to time shall be procured and used on the work. Joint account of cement consumed at site for every day for items of work carried shall be maintained by the Contractor for verification to ensure effective control on quality of cement used in the work.

A certified report attesting to the conformity of the cement to IS specifications by the cement manufactures chemist shall be furnished to the Engineer-in-charge, if demanded. In case the cement is required to be arranged by the Contractor, the Contractor will have to make his own arrangement for the storage of adequate quantity of cement. Cement in bulk may be stored in bins or silos which will provide complete protection from dampness, contamination and minimize caking and false set. Cement bags shall be stored in a dry enclosed shed (storage under tarpaulins will not be permitted), well away from the outer walls and insulated from the floor to avoid contact with moisture from ground and so arranged as to provide ready access. Damaged or reclaimed or partly set cement will not be permitted to be used and shall be removed from the site. The storage bins and storage arrangements shall be such that there is no dead storage. Not more than 12 bags shall be stacked in any tier. The storage arrangement shall be got approved by the Engineer-in-charge. Consignments in cement shall be stored as received and shall be consumed in the order of their delivery. Contractor shall establish cement/concrete/soil testing laboratories at site of work with qualified person to handle the laboratory. Every consignment of cement procured shall accompany test certificate from the company indicating lot No etc. Sample shall be

taken for each lot and sent to Standard Approved Material Testing Laboratory for physical and chemical analysis. The cost of testing shall be borne by the Contractor.

Cement held in store for a period of 90 (ninety) days or longer shall be retested before use in work. Should at any time the Engineer-in-charge have reasons to consider that any cement is defective, then irrespective of its origin and / or manufacturers test certificate, such cement shall be

tested immediately at a National Test Laboratory / Departmental Laboratory or such approved laboratory, and until the results of such tests are found satisfactory, it shall not be used in any work.

Aggregates:

"Aggregate" in general designates both fine and coarse inert materials used in the manufacture of concrete.

"Fine Aggregate" is aggregate most of which passes through 4.75 mm I.S. sieve.

"Coarse Aggregate" is aggregate most of which is retained on 4.75 mm I.S. sieve.

All fine and coarse aggregates proposed for use in the work shall be subject to the

Engineer-in-charge's approval and after specific materials have been accepted, the source of supply of such materials shall not be changed without prior approval of the Engineer-in-charge. Aggregate shall, except as noted above, consist of natural sand, crushed stone and gravel from a source known to produce satisfactory aggregate for concrete and shall be chemically inert, strong, hard, curable against weathering, of limited porosity and free from deleterious materials that may cause corrosion to the reinforcement or may impair the strength and / or durability of concrete. The grading of aggregates shall be such as to produce a dense concrete and shall be based on the "mix design" and preliminary test on concrete specified hereinafter.

Sampling and Testing:

Sampling of the aggregates for mix design and determination of suitability shall be taken under the supervision of the Engineer-in-charge and delivered to the laboratory, well in advance of the schedule placing of concrete. Record of tests which have been made on proposed aggregates and on concrete made from this source of aggregates shall be furnished to the Engineer-in-charge in advance of the work or use, in determining suitability of the proposed aggregate.

Storage of aggregates:

All coarse and fine aggregates shall be stacked separately in stock pile in the material yard near the work site in bins properly constructed to avoid inter mixing of different aggregates. Contamination with foreign materials and earth during storage and while heaping the materials shall be avoided. The aggregate must be of specified quality not only at the time of receiving at site but also at the time of loading into mixer. Rakers shall be used for lifting the coarse aggregate from bins or stock piles. Coarse aggregate shall be piled in layers not exceeding 1.00 meters in height to prevent

conning or segregation. Each layer shall cover the entire area of the stock pile before succeeding layers are started. Aggregates that have become segregated shall be rejected. Rejected materials after remixing may be accepted, if subsequent tests demonstrate conformity with required gradation.

Specific Gravity:

Aggregates having a specific gravity below 2.6 (saturated surface dry basis) shall not be used without special permission of the Engineer-in-charge.

Fine Aggregate:

Fine aggregate except as noted above, and for other than light weight concrete shall consist of natural or crushed sand conforming to IS 383. The sand shall be clean, sharp, hard, strong and durable and shall be free from dust, vegetable substances, adherent coating, clay, loam, alkali, organic matter mica, salt or other deleterious substances which can be injurious to the setting qualities / strength / durability of concrete.

Screening and Washing:

Sand shall be prepared for use by such screening or washing or both as necessary, to remove all objectionable foreign matter while separating the sand grains to the required size fractions. Sand with silt content more than 3 percent will not be permitted to be used unless same is washed and silt content is brought within 3% by weight.

GRADATION: Unless otherwise directed or approved, the grading of sand shall be within the limit indicated here under:-

Where the grading falls outside the limits of any particular grading zone of sieves, other than 600 micron (IS) sieve by not more than 5% it shall be regarded as falling within that grading zone. This tolerance shall not be applied to percentage passing the 600 micron (IS)

sieve or to percentage passing any other sieve size on the coarser limit of grading zone I or the finer limit of grading zone IV. Fine aggregates conforming to Grading zone IV shall not be used unless mix designs and preliminary tests have shown its suitability for producing concrete of specified strength and workability.

Fineness Modulus:

The sand shall have a fineness modulus of not less than 2.2 or more than 3.2 the fineness modulus is determined by adding the cumulative. Percentages retained on the following IS sieve sizes (4.75 mm, 2.36 mm, 1.18mm, 600 micron, 300 micron and 150 micron) and dividing the sum by 100.

Coarse Aggregate:

Coarse aggregate for concrete except as noted above and for other than light weight concrete shall conform to IS 383. This shall consist of natural or crushed stone and gravel, and shall be clean and free from elongated, flaky or laminated pieces, adhering coatings, clay lumps, coal residue, clinkers, sag, alkali, mica, organic matter or other deleterious matter. The coarse aggregate and fine aggregate shall be tested from time to time as required by the Engineer-in-charge to ascertain its suitability for use in construction and the charges for testing aggregate shall be born by the contractor as specified herein after.

Screening and Washing:

Crushed rock shall be screened and / or washed for the removal of dirt or dust coating, if so demanded by Engineer-in-charge.

Grading:

Coarse aggregates shall be either in single or graded in both the cases. The grading shall be within the following limits:

IS Sieve designation	Percentage passing for single sized aggregates						Percentage passing for graded aggregates of nominal size			
	63mm	40mm	20mm	16mm	12.5mm	10mm	40mm	20mm	16mm	12.5mm
75mm	100	-	-	-	-	-	-	-	-	-
63mm	85-100	100	-	-	-	-	100	-	-	-
37.5mm	0-30	85-100	100	-	-	-	95-100	100	-	-
19mm	0.5	0.20	85-100	100	-	-	30-70	95-100	100	100
16mm	-	-	-	85-100	100	-	-	-	90-100	-
11.2mm	-	-	-	-	85-100	100	-	-	-	90-100
9.5mm	-	0.5	0.20	0.30	0-45	85-100	10-35	25-55	30-70	40-85
4.75mm	-	0.5	0-5	0-10	0-20	0-20	0-5	0-10	0-10	0-10
2.36mm	-	-	-	-	0-5	0-5	-	-	-	-

Foreign Material Limitations:

The percentages of deleterious substances in the coarse aggregate delivered to the mixer shall not exceed the following.

Sl. No.	Substances	Percent by weight	
		Uncrushed	Crushed
I	Material finer than 75 micron IS Sieve	3.00	3.00
II	Coal and Lignite	1.00	1.00
III	Clay lumps	1.00	1.00
IV	Soft fragments	3.00	-
V	Total of all the above substances	5.00	5.00

Water:

Water used for both mixing and curing shall be free from injurious amount of deleterious materials; potable waters are generally satisfactory for mixing and curing concrete. In case of doubt, the suitability of water for making concrete shall be ascertained by the compressive strength and initial setting time test specified in IS 456. The sample of water taken for testing shall be typical of the water proposed to be used for concreting, due account being paid to seasonal variation. The samples shall not receive any treatment before testing other than that envisaged in the regular supply of water proposed for use in concrete. The sample shall be stored in a clean container previously rinsed out with similar water. Average 28 days compressive strength of at least three 150mm concrete cubes prepared with water proposed to be used shall not be less than 90% of the average strength of three similar concrete cubes prepared with distilled water. The initial setting time of test block made with the appropriate test cement and the water proposed to be used shall not be less than 30 minutes and shall not differ by more than (+) 30 minutes from the initial setting time of control test block prepared with the appropriate test cement and distilled water. The test blocks shall be prepared and tested in accordance with the requirements of IS 4031. Where water can be shown to contain an excess of acid, alkali, sugar or salt, Engineer-in-charge may refuse to permit its use. As a guide, the following concentrations represent the maximum permissible values.

Limits of acidity:

To neutralize 200ml sample of water, using phenolphthalein as an indicator, it should not require more than 2ml of 0.1 normal NaOH. The details of test shall be as given in IS 3025.

Limits of alkalinity:

To neutralize 200ml sample of water, using methyl orange as an indicator, it should not require more than 10ml of 0.1 normal HCL. The details of test shall be as given in IS 3025.

Design Mix Concrete:

All reinforced concrete in the works shall be "Design Mix Concrete" as defined in I.S. 456-2000. All "Design Mix Concrete" work to be carried out under these specifications shall be in grades designated as per table below:

Grades of Concrete:

Grade Designation	Specified Characteristic compressive strength at 28 days(N/mm ²)
M 10	10
M 15	15
M 20	20
M 25	25
M 30	30
M 35	35
M 40	40

Mix Design:

This is to investigate the grading of aggregates, water cement ratio, workability and the quantity of cement required to give works cubes of the characteristic strength specified. The proportion of the mix shall be determined by weight. Adjustment of aggregate proportions due to moisture present in the aggregate shall be made. **Mix proportioning shall be carried out according to the ACI standard designation ACI-613 or Design of concrete mixes –**

Road research Note No. 4, Department of Scientific and Industrial Research U.K. or I.S. 10262-1982.

Selection of Water Cement Ratio:

Since different cements and aggregates of different maximum size, grading, surface texture, shape and other characteristics may produce concretes of different compressive strength for the same free water cement ratio, the relationship between strength and free water cement ratio should preferably be established for the materials actually to be used. In the absence of such data, the preliminary free water cement ration (by mass) corresponding to the target strength of 28 days may be selected from the relationship shown in Fig. 1 of IS. 10262- page 7. Alternately, the preliminary free

water ratio (by mass) corresponding to the target average strength may be selected from the relationship in Fig2-IS 10262-1982, Page 8 using the curve corresponding to the 28 days cement strength to be used for the purpose. Other relevant items to be used with design of mix should strictly conform to the relevant clauses and appendices of IS 10262 – 1982.

Mode of Measurement for concrete work:

General:

Concrete as actually done shall be measured for payment, subject to the following tolerances, unless otherwise stated hereinafter. Any work done extra over the specified dimensions shall not be measured for payment.

- a. Linear dimensions shall be measured in full centimeters except for the thickness of slab which shall be measured to the nearest half centimeter.
- b. Areas shall be worked out to the nearest 0.01 sqm.
- c. Cubic contents shall be worked out to the nearest 0.001 cum.
- d. The concrete shall be measured for its length, breadth and height/depth limiting dimensions to those specified on drawings or as directed by the Engineer-in-charge.

Note: The sizes of RCC members as assumed in to estimate are based on preliminary drawings and are likely to be changed. The contractor is not entitled to any extra claim due to such changes.

Deductions:

No deduction shall be made for the following:

- a. Ends of dissimilar materials e.g. joists, beams, posts, girders, rafters, purlins, trusses, corbels, steps etc. up to 500 sq.cm in cross section.
- b. Opening up to 0.1 sqm. (1000 sq.cm).
- c. Volume occupied by reinforcement.
- d. Volume occupied by pipes, conduits, sheathing etc. not exceeding 25sq.cm. each in cross sectional area. Nothing extra shall be paid for leaving and finishing such cavities and holes.

Column Footing:

R.C.C. in foundation and footings shall be measured for its length, breadth and depths limiting dimensions to those specified in drawing or as ordered in writing by the Engineer-in-charge. In case of tapering portions of column footings, the quantities shall be calculated by Prismoidal Formula.

Column:

Column shall be measured from top footings to the plinth level and from plinth level to the structural slab level and to the subsequent structural slab levels. Measurements for higher grade concrete in column at its junction with lower grade concrete beams shall be restricted to the column section supporting the beam in question.

Wall:

All walls shall be measured from top of the wall footing to the plinth level and from plinth level to the top of structural first floor and to subsequent floors.

Beam and Lintel:

Beam shall be measured from face to face of the columns, walls, cross beams including haunches if any. The depth of the beams shall be measured from the top of the slab to the bottom of the beam except in the case of inverted beam where it shall be measured from top of slab to top beams. The beams and lintels with narrow width even though acting as fascia in elevation in some cases will be measured as beams and lintels only.

I) Slab:

The length and breadth of slab laid to correct thickness as shown in the detailed drawing for as ordered by the Engineer-in-charge shall be measured between beams, walls and columns.

II) Chajjas, Facias, Fins and Mullions:

- a. Chajjas shall be measured net from supporting faces up to the edges of chajjas without any fascia.
- b. Facia shall be measured full excluding chajja thickness.
- c. End fins shall be measured full.

d. Intermediate fins, mullions shall be measured between chajjs or other supporting structural members.

e. Parapets shall be measured from top of slab / chajja.

III Staircase:

The concrete in all members of staircase like waist slabs, steps, cantilever steps, stringer beams etc. shall be measured for their length, breadth and depth, limiting dimensions to those specified on drawings. No deductions shall be made for embedded plugs, pockets.

Rates:

The rate for PCC / RCC shall include the cost of all materials, labour, transport, tools and plants and all the operations mentioned hitherto, including or excluding the cost of form work and / or reinforcement as mentioned in the schedule for quantities. The rates also shall include the cost of testing material, mix design; cube test and allied incidental expenses. The reinforcement steel used in the works shall be measured and paid for separately under relevant item.

4.2.5 FORM WORK

General:

The form work shall consist of shores, bracings, sides of beams and columns, bottom of slabs etc, including ties, anchors, hangers, inserts etc. complete which shall be properly designed and planned for the work. The false work shall be so constructed that up and down vertical adjustment can be made smoothly. Wedges may be used at the top or bottom of timber shores, but not at both ends, to facilitate vertical adjustment and dismantling of form work.

Design of Form Work

The design and engineering of form work as well as its construction shall be the responsibility of Contractor. The drawings and calculations for the design of the form work shall be submitted well in advance to the Engineer-in-charge for approval before proceeding with work, at no extra cost to the Department. Engineer-in-charge's approval shall not however, relieve Contractor of the full responsibility for the design and construction for the form work. The design shall take into account all

the loads vertical as well as lateral that the forms will be carrying including live and vibration loadings.

Tolerances:

Tolerances are specified permissible variation from lines, grade or dimensions given in drawings. No tolerances specified for horizontal or vertical buildings lines or footings. Unless otherwise specified, the following tolerances will be permitted.

Tolerances for R.C. Buildings:

I) Variation from the plumb:

a) In the line ad surfaces of columns, piers, walls and in buttresses: 5 mm per 2.5m, but not more than 25 mm.

b) For exposed corner columns ad other conspicuous lines

In any bay or 5 m, maximum : (+) 5 mm In 10 m or more: (+) 10mm

ii) Variation from the level or from the grades indicated on the drawings.

a) In slab soffits, ceilings, beam soffits and in arises.

b) In 2.5m (+) 5mm

In any bay or 5m maximum (+)

8 mm In 10 or more (+) 15mm

c) For exposed lintels, sills, parapets, horizontal grooves and conspicuous lines

iii) Variation of the linear building lines from established position in plan and related position of columns, walls and partitions. In any bay or 5m maximum (+) 10 mm In 10 or more (+) 20mm

iv) Variation in the sizes ad locations of sleeves, openings in walls and floors except in the case of and for anchor bolts : (+) 5mm

v) Variation in cross sectional dimensions of columns and beams and in the thickness of slabs and walls: (+) 10 mm/(-)5mm

vi) Footing :

- a) Variation in dimensions in plan (+) 50mm/(-) 5mm.V- Page 55 of 197
- b) Misplacement or eccentricity: 2% of footing within the direction of misplacement but not more than 50mm.
- c) Reduction in thickness (-) 5% of specified thickness subject to maximum of 50mm.

vii) Variation in steps:

a) In a flight of stairs Rise (+) 3.0 mm

Tread (+) 5.0 mm

b) Consecutive steps Rise

(+) 1.5 mm Tread

(+)3.0 mm

4.2 STEEL REINFORCEMENT

Steel reinforcement bars, if supplied or arranged by contractor, shall be either plain round mild steel bars grade as per IS 432 (part-I) or medium tensile steel bars as per IS 452 (part-I) or hot rolled mild steel ad medium tensile steel deformed bars as per IS 1139 or cold twisted steel bars and hot weld strength deformed bars as per IS 1786, as shown and specified on the drawings. Wire mesh or fabric shall be in accordance with IS 1566. Substitution of reinforcement will not be permitted except upon written approval from Engineer-in-charge.

Storage :

The reinforcement steel shall not be kept in direct contact with ground but stacked on top of an arrangement of timber sleepers or the like. Reinforcement steel shall be with cement wash before stacking to prevent scale and rust. Fabricated reinforcement shall be carefully stock to prevent damage, distortion, corrosion ad deteriorations.

Quality :

All steel shall be grade I quality unless specifically permitted by the Engineer-incharge. No rolled material will e accepted. If demanded by the Engineer-in-charge. Contractor shall submit the manufacturers test certificate for steel. Random tests on steel supplied by contractor may be

performed by Department as per relevant Indian Standards. All costs incidental to such tests shall be at contractors expense. Steel not conforming to specifications shall be rejected. All reinforcement shall be clean, free from grease, oil, paint, dirt loose mill, scale dust, bituminous materials or any other substances that will destroy or reduce the bond. All rods shall be thoroughly cleaned before being fabricated. Pitted and defective rods shall not be used. All bars shall be rigidly held in position before concreting. No welding of rods to obtain continuity shall be allowed unless approved by the Engineer-in-charge. If welding is approved, the work shall be carried as per 2751, according to best modern practices as directed by the Engineer-in-charge in all cases of important connections, tests shall be made to prove that the joints are of the full strength of bars welded. Special specifications, as specified by the Engineer-in-charge, shall be adhered to in the welding of cold worked reinforcing bars and bars other than mild steel.

Laps :

Laps and splices for reinforcement shall be shown in the drawings. Splices, in adjacent bars shall be staggered and the locations of all splices, except those specified on the drawing shall be approved by the Engineer-in-charge. The bars shall not be lapped unless the length required exceeds the maximum available length of bars at site.

Bending :

All bars shall be accurately bent according to the sizes and shapes shown on the detailed working drawings/ bar bending schedules. They shall be bent gradually by machine or other approved means. Reinforcing bars shall not be straightened and rebent in a manner that will injure the materials. Bars containing cracks or splits shall be rejected. They shall be bent cold, except bars of over 25mm in diameter which may be bent hot if specifically approved by the Engineer-in-charge. Bars bent hot shall not be heated beyond cherry red colour (not exceeding 645°C) and after bending shall be allowed to cool slowly without quenching. Bars incorrectly bent shall be used only if the same means used for straightening and rebinding be such as shall not, in the opinion of the Engineer-in-charge injure the material. NO reinforcement bar shall be bent when in position in the work without approval, whether or not it is partially embedded in hardened concrete. Bars having links or bends other than those required by design shall not be used.

Bending at Construction Joints :

Where reinforcement bars are bent aside at construction joints and afterwards bent back into their original position, care should be taken to ensure that no time the radius of the bend is less than 4 bar diameters for plain mild steel or 6 bar diameters for deformed bars. Care shall also be taken when bending back bars to ensure that the concrete around the bar is not damaged.

Fixing / Placing and Tolerance on Placing :

Reinforcement shall be accurately fixed by any approved means maintain in the correct position as shown in the drawings by the use of blocks, spacer and chairs as per IS 2502 to prevent displacement during placing and compaction of concrete. Bars intended to be in contact at crossing point shall be securely bound together at all such points with number

16 gauge annealed soft iron wire. The vertical distances required between successive layers of bars in beams or similar members shall be maintained by the provision of mild steel spacer bars at such intervals that the main bars do not perceptibly sag between adjacent spacer bars.

Tolerance on placing of reinforcement :

Unless otherwise specified by the Engineer-in-charge, reinforcement shall be placed within the following tolerances:

Tolerance in spacing

- a) For effective depth, 200 mm or less + 10 mm
- b) For effective depth, more than 200 mm + 15 mm

Cover to Reinforcement :

The cover shall in no case be reduced by more than one third of specified cover or 5mm whichever is less. Unless indicated otherwise on the drawings, clear concrete cover for reinforcement (exclusive of plaster or other decorative finish shall be as follows) :

- a) At each end of reinforcing bar not less than 25 mm, nor less than twice the diameter of such bar.
- b) For a longitudinal reinforcing bar not less than 25 mm, nor more than 40 mm, nor less than the diameter of such bar. In the case of column of maximum dimensions of 200mm or under, whose reinforcing bars do not exceed 12mm, a cover of 25mm may be used.

- c) For longitudinal reinforcing bar in a bar, not less than 25 mm nor less than the diameter of such bar and.
- d) For tensile, compressive, shear, or other reinforcement in a slab, not less than 25mm, nor less than the diameter of such bar and.
- e) For any other reinforcement not less than 15mm, nor less than the diameter of such bar.
- f) Increased cover thickness may be provided when surfaces of concrete members are exposed to the action of harmful chemicals (as in the case of concrete in contact with earth faces contaminated with such chemicals), acid, vapour, saline, railways) etc. and such increase of cover may be between 15mm and 50 mm beyond the figures given in (a to e) above as may be specified by the Engineer-in-charge.
- g) For reinforced concrete members, totally immersed in sea water the cover shall be 40mm, more than specified (a to e) above.
- h) For reinforced concrete members, periodically immersed in sea water or subject to sea spray, the cover of concrete shall be 50 mm more than that specified (a to e) above.
- i) For concrete of grade M25 and above, the additional thickness of cover specified in (f), (g) and (h) above may be reduced to half. In all such cases the cover should not exceed 75mm.
- j) Protection to reinforcement in case of concrete exposed to harmful surroundings may also be given by providing a dense impermeable concrete with approved protective coating as specified on the drawings. In such case, the extra cover, mentioned in (h) and (i) above, may be reduced by the Engineer-in-charge, to those shown on the drawing.
- k) The correct cover shall be maintained by cement mortar briquettes or other approved means. Reinforcement for footings, grade beams and slabs on sub grade shall be supported on precise concrete blocks as approved by the Engineer-in-charge. The use of pebbles or stones shall be permitted.
- l) The minimum clear distance between reinforcing bars shall be in accordance with IS 456 or as shown in drawings.

4.3 STRUCTURAL STEEL

Scope of Work :

The work covered by this specification consists of furnishing and erecting of structural steel complete in strict accordance with this specifications and the applicable drawings.

Materials:

All structural steel shall be of standard sections as marked on the drawings and shall be free of scale, blisters, laminations, cracked edges and defects of any sort. If the structural steel is not supplied by the Department and the Contractor is required to bring such steel, the Contractor shall furnish duplicate copies of all mill orders and / or also the test report received from the mills, to satisfy the Engineer-in-charge. All structural steel and electrodes shall comply in all respects with relevant I.S.S. for structural steel.

Workmanship:

All workmanship shall be of first class quality in every respect to get greatest accuracy to ensure that all parts will fit together properly on erection. All ends shall be cut true to planes. They must fit the abutting surfaces closely. All stiffeners shall fit tightly at both ends. All holes in plates and section between 12mm and 20 mm thick shall be punched to such diameter that 3mm of metal is left all around the hole to be cleaned out to correct size by reamer.

The base connection shall be provided as shown on drawings and the greatest accuracy of workmanship shall be ensured to provide the best connections. Figured dimensions on the drawings shall be taken.

Erection and Marking:

Erection and fabrication shall be according to IS 800-1984 section -11. During erection, the work shall be securely braced and fastened temporarily to provide safety for all erection stresses etc. No permanent welding shall be done until proper alignment has been obtained. Any part which do not fit accurately or which are not in accordance with the drawings and specifications shall be liable to rejection and if rejected, shall be at once be made good. Engineer-in-charge shall have full liberty at all reasonable times to enter the contractors premises for the purpose of inspecting the work and no

work shall be taken down, painted and dispatched until it has been inspected and passed. The contractor shall supply free of charge all labour and tools required for testing of work.

Delivery at Site :

The contractor shall deliver the component parts of the steel work in an undamaged state at the site of the works and the Engineer-in-charge shall be entitled to refuse acceptance of any portion which has been bent or otherwise damaged before actual delivery on work.

Shop Drawing :

The shop drawings of structural steel based on contract drawings shall be submitted to the Engineer-in-charge. The necessary information for fabrication, erection, painting of structure etc. must be furnished immediately after acceptance of the tender.

Painting :

Painting should be strictly according to IS. 1477-1971 (Part-I-Pretreatment) and IS 1477-1971 (part-II painting). Painting should be carried out on dry surfaces free from dust, scale etc. The paint shall be approved by the Engineer-in-charge. One coat of shop paint (red lead) shall be applied on steel, except where it is to be encased in concrete or where surfaces are to be field welded.

Welding :

Welding shall be in accordance with IS. 816-1969, IS 819-1957, IS 1024-1979, IS 1261-1959, IS 1323-1982 and IS 9595-1980 as appropriate. For welding of any particular type of joint, welders shall give evidence of having satisfactorily completed appropriate test as described in any of IS 817-1966, IS 1393-1961, IS 7307 (part-I) –1974, IS 7310 (part-I) 1974 and IS 7318 (part-I) 1974 as relevant.

Welding Consumables:

Covered electrodes shall conform to IS 814 (part-I) – 1974 and IS 814 (part-II)- 1974 or IS 1395-1982 as appropriate. Filler rods and wires for gas welding shall conform to IS 1278-1972. The bar wire electrodes for submerged arc welding shall conform to IS 7280-1974. The combination of arc and flash shall satisfy the requirements of IS 3613-1974.

The filler rods and bare electrodes for gas shielded metal, arc welding shall conform to IS 6419-1971 and IS 6560-1972 as appropriate .

Type of Welding :

Are welding (direct or alternating current) or Oxyacetylene welding may used. Field welding may be used. Field welding shall be by D.C.

4.4 DAMP PROOF COURSE

Scope of work:

The work covered under this specifications consists supplying and laying plain cement concrete or cement plaster 1:3 as damp proof course with or without waterproofing admixture with this specification and applicable drawings.

Workmanship :

Surface to receive damp proof course shall be cleaned and carefully wiped to remove all dust, laitance etc. and shall be approved by the Engineer-in-charge Damp proof course shown shall be cement concrete as per proportion indicated in the schedule or cement

plaster in the ratio CM 1:3. Approved water proofing compound @ 2% by weight of cement or as directed by the manufacturer shall be mixed in cement mortar for this concrete or plaster. The damp proof course shall be laid to the full width of the walls and the edges shall be straight, even and truly vertical. Wooden forms shall be used to obtain good edges. No masonry work shall be commenced on freshly laid damp proof course unless it is cured for 48hours of its laying by curing of damp proof course shall be continued along with the masonry work. Specification for cement, sand, aggregate and water shall be as described herein before for concrete works / cement plaster.

Mode of measurement :

The work shall be measured in sqm. area actually laid limited to sites as shown in drawing. The rate shall include cost of all the materials, labour etc. and scaffolding (if any).

4.5 BRICK WORK

Scope of work:

The work covered under this specification pertains to procurement of best quality locally available bricks and workmanship of building walls of various thickness. In strict compliance with the specifications and applicable drawings.

Materials :

Brick shall be best quality locally available bricks and shall be got approved by the Engineer-in-charge before incorporation in the work. The nominal size of bricks (F.P.S) shall be 22.9 X 11.4 X 7cm (9" X 4 1/2 X 2 3/4"). Permissible tolerance on dimensions shall be + 3mm. in length and + 1.5 mm in width / thickness. The contractor shall get approved the sample and source of bricks from Engineerin- charge before procurement on large scale and shall maintain the same for the entire work. In case the size of bricks used in the work found lesser than the specified one for the whole lot : Extra cement consumed due to more number of joints and due to additional thickness of plaster than the specified in the tender to match with adjoining columns and beams, shall be to contractor's account. If the plastering to be done is more than the specified thickness to bring the plaster surface to perfect line, level ad plumb with adjoining columns, beams walls etc., the contractor shall be responsible to provide and fix chicken wire mesh to receive more thickness of plaster at his own cost and nothing extra will be paid on this account.

In case the size of bricks used in the work, found more than the permissible, the contractor shall chip out the exposed edges of bricks upto the required level of wall to receive specified thickness of plaster at no extra cost. Bricks shall generally conform to IS 1077-1970. In any case minimum crushing strength shall not be less than 35 kg/sq.cm and water absorption shall not be more than 25% by weight. The Engineer-in-charge shall have the right to reject bricks obtained from any field where the soil have an appreciable quantity of sulphates and chlorides. The specifications for cement, sand and water shall be same as described herein before under cement concrete. Bricks shall be thoroughly soaked in water before using till the bubbles ceases. No half or quarter brick shall be used except as closer. The closers shall be cut to required size and used near the end of the walls. The walls shall be raised truly to plumb.

The type of bond to be adopted shall be decided by the Engineer-in-charge, but vertical joints shall be laid staggered.

Workmanship :

Four courses of brick work with four joints should not exceed by more than 40mm the same bricks piled one over the other without mortar. Brick work shall not be raised more than 10 courses a day unless otherwise approved by the Engineer-in-charge. The brick work shall be kept wet for at

least 7 days. Brick work shall be uniformly raised around and no part shall be raised more than 1.0 metre above another at any time.

All joints shall be thoroughly flushed with mortar of mix as specified in the schedule of quantities, at every courses. Care shall be taken to see that the bricks are bedded effectively and all joints completely filled to the full depth. The joints of brick work to be plastered shall be raked out to a depth not less than 10mm as the work proceeds. The surface of brick work shall be cleaned down and wiped properly before the mortar sets.

The adhesion between the brick masonry surface and the concrete surface of columns, beams, chajjas, lintels etc. should be proper by ensuring that the concrete surface coming in contact with brick masonry is backed / chipped / keyed, cleaned and cement slurry is applied so that a proper bond is achieved between the two dissimilar materials. It is responsibility of the contractors to ensure that there will not be any cracks / fissure anywhere in the brick masonry. In case the cracks appear subsequently in those areas, they should be made good by cement grouting or epoxy putty grouting/ poly sulphide compound grouting or as per standard modern specifications/methods with the prior approval of the Engineer-in-charge, at the cost of the contractor. All the courses shall be laid truly horizontal and all vertical joints shall be truly vertical. Specified mortar of good and approved quality shall be used. Lime shall not be used where reinforcement is provided in brick work. The mortar should completely cover the bed and sides of the bricks. Proper care should be taken to obtain uniform mortar joint throughout the construction. The walls should be raised uniformly in

proper, approved bond. In construction of the wall, first of all two end corners are carefully laid to line and level and then the portion in between is built, with a cord stretching along the headers or stretchers held in position at the ends. This helps in keeping the alignment of the courses and maintaining them in level. Similarly all other courses are built. Care shall be taken to keep the perpend properly aligned within following maximum permissible tolerances :

Deviation from vertical within a storey shall not exceed 6mm per 3 m height Deviation in verticality in total height of any wall for building more than one storey in height shall not exceed 12.5 mm. Deviation from position shown on plan of any brick work shall not exceed 12.5 mm. Relative displacement between load bearing wall in adjacent storeys in the end to be vertical alignment shall not exceed 6mm. A set of tools comprising of wooden straight edge, masonry spirit level, square, 1 meter rule line and plumb shall be kept on the site of work for every 3 masons for proper check during the progress of work. No brick work shall be carried on during frosty weather except with the written permission of the Engineer-in-charge who will give special directions as to the manner in which the

work is to be performed. All brick work laid during the day shall, in seasons liable to frost, be properly covered up at night as directed by the Engineer-in-charge. Should any brick work be damaged by frost, the brick work shall, at the discretion of the Engineer-in-charge, be pulled down and made good at the cost of the contractor.

Concrete surfaces of columns, beams, lintels, chajjas etc. coming in contact with masonry work shall be properly chipped, washed and given a thick coat of cement slurry before start of work. The rate quoted shall include wire brushing and cleaning brick work covered with fungus or deleterious materials.

Brick work shall be well watered / cured throughout the day for at least a week from the date of building and the work shall be protected from sun and rain.

Materials and workmanship for a half brick or brick on edge partition wall shall be as specified above. The wall shall be stiffened by providing with 2 nos. 6mm diameter M.S. or as specified in the schedule as bottom reinforcement (only the M.S. reinforcement will be paid separately under relevant item).

The rates for brick work shall include the cost of the following :

Providing and fixing necessary single or double scaffolding and removing the same after the work is completed. Watering, curing, lifting of material to any height.

Raking out of joints to receive plaster. Forming slab sittings, cutting or leaving holes for lugs of windows, doors, sills, switch and plug boxes etc. Making good all holes, chases etc. to any depth due to conduit pipes, holdfasts, bolts, switch and plug boxes etc.

Bedding and pointing precast lintels, sills etc. in or on walls. For the purpose of measurements, the thickness of one brick wall and over shall be taken in terms of multiples of half brick.

Mode of measurement :

For Brick work measured in Cubic Metres :

The contract rate shall be for a unit of one cubic metre of brick masonry as actually done. For measurement purpose, thickness of single brick wall shall be taken as 215 mm. irrespective of thickness used. Brick walls of more than one brick thickness shall be measured as per actual thickness constructed. All opening in brick work for doors, windows and ventilators shall be

deducted to get the net quantity of actual brick work done. Opening or chases required for P.H. or electrical inserts less than 0.1 sqm. And bearing of precast concrete members shall not be deducted. No extra payment shall be made for any extra work involved in making the above openings or placements.

For Brick work measured in square metre :

Half brick thick masonry walls shall be measured in sqm. All openings in brick work for doors and windows and windows and ventilators shall be deducted to get the net quantity of actual work done. Openings of chases required for P.H. or Electric inserts less than 0.1 sqm. And bearing of precast concrete members shall not be deducted. No extra payment shall be made for extra work involved in making the above openings or placements.

4.6 STONE MASONRY

Scope of work:

The work covered under this specifications consists of supplying and erecting stone masonry walls with available best quality of stone in strict compliance with this specifications and applicable drawings.

Random Rubble Masonry :

Material :

The rubble shall be of the best quality trap / granite / ballast stones obtained from the approved quarry. The same of the stone, to be used shall be got approved from the Engineer in charge. All stones shall, generally be freshly quarried and shall be sound, dense, hard, free from segregation, cracks, weathered portions and other structural defects to requisite sections and forms and shall have fully dressed beds and joints. At least 50% of the stones shall be 0.015 cum.

in content when reckoned individually. The length of stones for stone masonry shall not

exceed three times the height not the breadth or base shall not be greater than three fourth the thickness of wall, or not less than 15cm. the height of stone may be upto 30 cm. stones shall be laid on the natural beds and shall run sufficiently inside the wall thickness. No hollow space shall be left out and inter spaces of stones being filled with mortar and stone chips, driven hard and not with mortar only.

All mortar to be used shall be of the type and proportion mentioned in the item. Cement, sand and water to be used shall conform to their relevant specifications as described under cement concrete. The masonry shall be laid plumb, lines levels, curves, shapes as shown in drawings. All required holes for passage of water or pipes are to be embedded during construction as specified. All stones shall be wetted before laying in masonry. Concrete surfaces of columns, beams, lintels, chajjas etc. coming in contact with masonry shall be properly chipped, washed and wetted before start of masonry work. The concrete slurry as the masonry work progresses in height. Clean chips and spawls carefully selected to fit in the space shall be wedged into the mortar. Joints and beds wherever necessary to avoid thick beds or joints or mortar. However, proper shaping and dressing of stones shall be done prior to their laying in masonry and hammering shall not be resorted to often after the stones are laid in position. The bond stones shall be used in every square metre area of masonry wall and shall extend from front to back to thin walls having width of 600 mm. and shall overlap by at least 150 mm. in walls having thickness more than 600mm. when laid from both sides.

When the work has to be started on the old or the one completed a long while ago or in the previous working seasons, care shall be taken to roughen and clean old surface satisfactorily without disturbing the masonry before laying the new. It shall be wetted before laying the bedding mortar. When practicable, the whole masonry in any structure shall be carried out upto a uniform level throughout. But when breaks are unavoidable in carrying the work continuously in uniform level, sufficiently long steps shall be left. All junction of walls shall be formed at the time when walls are being built. Cross walls should be carefully bonded in to the main walls. All masonry built in cement mortar shall be kept continuously wet for 14 days from the date of laying. Should the mortar perish i.e., becomes dry, white or powder through neglect of watering if the masonry shows hollow joints or non adherence of mortar to the stones or if the work does not conform to drawings and specifications, the work shall be pulled down and rebuilt by the contractor at his own cost and risk. All masonry shall be thoroughly cleaned and washed down on completion and all stains, adhering mortar removed from the surface and raking of joints carried out as the scaffolding is being lowered and removed. Holes left in masonry for supporting scaffolding shall be filled and made good before pointing / plastering.

Mode of measurement :

All stone masonry shall be measured in cubic metres as actually done. All openings for windows, doors, lintels etc. shall be deducted to get the net quantity of actual work done. Openings or chases required for P.H. and electrical inserts less than 0.1 sqm. and bearings of precast concrete

members shall not be deducted. The ate shall also include cost of corner stones, bond stone, scaffolding, labour, curing etc.

FLOORING

Scope of work:

The work covered under this specification consists of providing and laying at levels and floors, flooring of different types, strictly in accordance with these specifications and relevant drawings.

Cement Concrete Flooring (Indian Patent Stone) :

Materials :

The specifications for materials, grading, mixing and the quantity of water to be added shall generally conform to their relevant specifications described under plain and reinforced concrete. The maximum size of coarse aggregate shall be 10mm. The fine aggregate shall consist of properly graded sand. Concrete shall be mixed preferably by machine, and hand mixing shall be avoided as far as practicable.

Preparation of Base :

The base concrete surface shall be thoroughly chipped to remove laitance, caked mortar, loose sand, dirt etc. cleaned with wire brush and washed clean and watered until no more water is absorbed. Where the base concrete has hardened so much that roughening the surface by wire brushes is not possible, the same shall be roughened by chipping or hacking at close intervals. The surface shall be soaked with water for atleast 12 hours and surface water removed and dried before laying the topping. Before laying the concrete, cement slurry at 2.75 kg/ sqm. of surface shall be applied before laying the topping. Before laying the concrete, cement slurry at 2.75 kg. / sqm. of surface shall be applied for better bond, / flush as per drawings. The edge of each panel into which the floor is divided shall be supported by wooden or metal strips duly oiled to prevent sticking. The panels shall be of uniform size and, unless otherwise specified, no dimension of panel shall exceed 2 m. and the area of a panel shall not be more than 2 sqm. However, the exact size of panel shall be decided by the Engineer-in-charge to suit the size of the room. The joints in the floor finish shall extend through the borders a skirting/ dado. The border shall have mitred joints at the corners of the room. Where aluminium dividing strips are proposed to be provided, the same shall be fixed in cement mortar 1:2 @ 1200 mm. centers or as specified in the schedule for full depth of the finished floor. The depth of dividing strips

shall be the thickness as proposed for the finished floor in the item. In the case of flush joints, alternate panels only may be cast on same day.

Atleast 48 hours shall elapse before the concreting of adjacent bay is commenced.

Mixing :

The topping concrete shall be of mix of one part of cement, two parts of sand and 4 parts of well graded stone chips of 10mm maximum size. the ingredients shall be thoroughly mixed with just sufficient water to the required plasticity, having water cement ratio not more than 0.4

Laying :

The free water on the surface of the base shall be removed and a coat of cement slurry to the consistency of thick cream shall be brushed on the surface. On this fresh grouted base, the prepared cement concrete shall be laid immediately after mixing. The concrete shall be spread and leveled carefully. The concrete shall be compacted and brought to the specified levels by means of a heavy straight edge resting on the side forms and down ahead with a sawing motion in combination with a series of lifts and drops alternatively with small lateral shifts, either mechanically or manually as directed by the Engineer-in-charge. While concreting the adjacent bays, care shall be taken to ensure that the edges of the previously laid bays are not broken by carelessness or hand tamping. Immediately after laying the concrete, the surface shall be inspected for high or low spots and correction needed shall be made up by adding or removing the concrete and whole surface is again leveled. When the layer is made even, the surface shall be completed by ramming or beating ad then screed to a uniform line and level. Before the initial set commences, the surface shall be sprinkled directly or empty gunny bags spread over the surface of the concrete to absorb excess water coming on top due to floating.

Finishing the surface:

After the concrete has been fully compacted, it shall be finished by troweling or floating. Finishing operations shall start shortly after the compaction of concrete an shall be spread over a period of one to six hours depending upon the temperature ad atmospheric conditions. The surface shall be trowelled intermittently at intervals for several times so as to produce a uniform and hard surface. The satisfactory resistance of floor to wear depends largely upon the care with which troweliing is carried out. The object of trowelling is to produce as hard and close knit a surfaces possible. The time interval allowed between successive trowelling is very important. Immediately

after laying only just sufficient trowelling shall be done to give a level surface. Excessive trowelling in the earlier stages shall be avoided as this tends to work a layer rich in cement to the surface, some time. After the first trowelling, the duration depending upon the temperature, atmospheric conditions and the rate of setting of cement used, the surface shall be retrowelled many times at intervals to close any pores in the surface shall be retrowelled many times at intervals to close any pres in the surface, and to bring to surface and scrap off any excess water in concrete or laitance (it shall not be trowelled back into the topping). The final trowelling shall be done well before the concrete has become too hard but at such a time that considerable pressure is required to make any impression on the surface. Trowelling of rich mix of dry cement. and fine aggregate on to the surface shall not be permitted. Trowel marks should not be seen on the finished surface. Where broom finish is specified, after the concrete has been thoroughly compacted, and when most of the surface water has disappeared, the surface shall be given broom finish with an approved type of brass or M.S. Fiber. The broom shall be pulled gently over the surface from edge to edge in such a manner that corrugation shall be uniform in width and depth, the depth shall be not more than 1.5 mm. Bromming shall be done when the concrete is in such ac condition that the surface will not be torn or unduly roughened by the operation. Coarse or long bristles which cause irregularities or deep corrugation shall be timed out. Brooms which are worn or other wise unsatisfactory shall be discarded.

After the concrete in the bays has set, the joints of the panels should be filled with cement cream and neatly floated smooth or jointed. Care should be taken that just the minimum quantity of cream for joint is used a excess spilling over the already finished surface shall be removed when the cream is still green. Incase of wide joints the same shall be filled with pigmented cement concrete (1:2:4) using approved pigment ad the joint shall be finished in perfectly straight line.

Steel Trowel Finish:

Areas where marbles tiles are proposed to be used are required to have base concrete finished smooth by steel trowel

Curing :

The completed flooring shall be protected from sun, wind and rain for the first two days and movement of persons over the floor is prohibited during this period. The finished surface shall be covered and cured continuously from the next day after finishing, at least for a period for 7 days. Bunding with murrum for curing is prohibited as it will leave permanent stain on the finished floor. Cure shall be done by spreading sand ad kept damp throughout the curing period of seven days minimum. The surface shall be protected from any damage to its whatsoever. The surface shall then

be allowed to dry slowly. All corners, junctions of floor with plastered wall surface shall be rounded off when required at no extra cost.

Mode of measurement :

The rate for flooring and skirting shall be in square metre of the area covered. The length and width of the flooring shall be measured not between the faces of skirting or dado or plastered faces of walls which is the proudest. All openings in flooring exceeding 0.1 sqm. in areas where flooring is not done shall be deducted and net areas only shall be measured and paid for. Flooring under dado, skirting or plaster shall not be measured for payment. Nothing extra shall be paid for laying the floor at different levels in the same room. The dimensions shall be measured upto places of decimals of a metre and area worked out upto two places of decimal of a square meter.

4.8 CEMENT PLASTERING FOR WALLS AND CEILINGS & SAND FACE

PLASTERS

Scope of work:

The work covered under these specifications consists of supplying all material for rendering all types of plaster / pointing finishes strictly in accordance with these specifications, applicable drawings etc.

General :

Cement, sand and water required for the work shall conform to specifications laid down herein before under section cement concrete (plain and reinforced), except that sand for finishing coat shall generally conform to IS 1542-1960. the plastering works shall generally conform to IS 1661-1987(pt.III) Code of practice for cement plaster finish on walls and ceilings). All general precautions as specified in I.S. 1661-1987 (pt.III) clause 8, shall be taken and preparation of the background shall be done as laid down in IS 1661 clause 12 and IS 2402- 2963 shall be generally followed for sand faced plaster work. Scaffolding required for facility of working shall be provided by the contractor at his own cost. This may be double or single according to the requirement and shall be approved by the Engineer-incharge stage scaffolding shall be erected when ceiling plastering is done. The contractor shall be responsible for accidents if any, take place. The contractor shall co-operate with the other agencies for fixing switch boxes at specified locations so that the boxes are fixed properly in line with finished plaster surface. All

finishing in and around these boxes as also around the conduit boxes in ceiling shall be done by plastering contractor without any extra cost to the Department. The decision of the Engineer-in-charge in this regard shall be final and binding on the contractor.

Preparation of Surface :

The surface to be plastered shall first be thoroughly cleaned of all muck and cleaned down. All joints shall be racked to in case of brick work / stone masonry and closely hacked in case of concrete as the work proceeds. The surface to be plastered shall be well wetted for a minimum period of 6 hours before commencing to work. The mortar for all plaster work shall be cement mortar of mix as specified in the schedule of quantities. After erection of scaffolding and before commencement of plastering work, top most junctions / joints / sides with beam / column shall be thoroughly packed with cement mortar to prevent cracks. Before commencement of plastering operation, the contractor shall ensure that all the service pipes, electrical conduits, boxes, switch boxes etc. have been installed in position by other agencies and the plastering surface is duly approved by the Engineer-in-charge. In order to enable other service contractors to fix the electrical conduit boxes, EDB's, pipes, outlets etc. in proper level and line with reference to the finished surface of the plaster. Thiyyas and Tapanis i.e. finished plaster patches shall be given by the main civil contractor on walls, ceiling at regular intervals well in advance of his plaster work at no extra cost to the Department. The entire work of preparation of surface before plastering shall thus be coordinated by the main civil contractor with all other agencies working at site. Just before actual plastering work is taken up in hand, all the ceilings and walls etc. shall be marked with plaster buttons indicating the thickness of plaster required and which shall be in true line, level and plumb. The contractor shall get these marks approved by the Engineer-in-charge before starting the plastering work. The contractor shall also be responsible to render the final surface true to line, level and plumb etc. All building operations like construction of walls, concreting etc. shall have been completed before plastering is taken up. The plastering operation should be taken up only after the service pipes etc. that are to be embedded in the wall or ceiling are completed and suitably protected against corrosion by other agencies and okayed by the Engineer-in-charge. Damage if caused to any of the existing fittings, fixtures, including doors and windows etc. during the plastering operation shall be made good by the contractor at his own cost. If the surface which is to be plastered either internally or externally is out of plumb and not in line and level and if the plastering to be done is more than specified thickness to bring the plastered surface to perfect line and levels in such specific cases, chicken wire mesh is to be provided by the contractor at his own cost and the plaster should be done to required line and level with no extra cost whatsoever. The finished plastered surface shall be free from cracks, fissures, crevices, hair cracks, blistering, local

swellings and flaking. The finished surface shall be true to line, level, plumb and plain and durable. The adhesion of the mortar with the background surface is of prime importance as this affects durability of plaster. Preparation of surface which has to take plastering work the surface should be got approved by the Engineer-in-charge. In order to avoid the formation of deep and side cracks and for dispersion for cracks at the junctions between concrete surfaces and brick masonry works, cautionary measures such as fastening and lapping of chicken mesh over the junction areas should be carried out over which the plastering work has to be taken up as required by the Engineer-in-charge. The minute gap between window / door frames with cills and jambs should be filled up / caulked by plaster of Paris / epoxy putty / silicon sealants, Rubber based sealants (brand name TECHMAT /TECHCOAT) by caulking guns or by approved methods as instructed / approved by Engineer-in-charge.

Groves :

The grooves shall be of required dimensions. The same shall be made to turn wherever necessary. The finish, inside, shall be of the same finish as that of the plaster. The lines of the grooves shall be well defined and rounded. The grooves are to be provided in plastering in internal and external surfaces shall be included in the rates wherever mentioned in the schedule of quantities.

Mix Proportion :

The mortar for plastering shall be of proportion as specified in the item schedule. The mixes specified in the schedule are volumetric.

Mixing :

Cement and fine aggregates shall be mixed dry in the required proportions to obtain a uniform colour. Water shall then be added to get the required consistency for the plaster. Mixing shall be done mechanically. However, manual mixing will be allowed only in exceptional circumstances at the discretion of the Engineer-in-charge. Manual mixing, where adopted, shall be carried out on a clean water tight platform. After water is added during mixing, the mix shall be held back and forth for 10 to 15 minutes. In machine mixing, the mixer shall run at least placing all the ingredients in the drum. Only so much quantity of mortar which can be used within half an hour after the addition of water shall be prepared at a time. Any mortar for plaster which is set or partially set shall be rejected and shall be removed from the site.

10mm Plaster :

The plaster shall be laid with somewhat more than 10mm, thickness and pressed and leveled with wooden ruler to a finished thickness of 10mm. Straight edges shall be freely used to ensure a perfectly even surface. All exposed angles and junctions of walls, doors, windows, beams, slabs etc. shall be carefully finished so as to furnish a neat and even surface.

15mm Plaster:

The proportions of sand and cement shall be as specified and shall cover all irregularities, undulations, depressions due to chasing etc. in the surface to be plastered. The mortar shall be applied slightly more than 15mm thick and pressed and leveled with wooden ruler or straight edge to finished thickness of 15mm. Straight edges shall be freely used to ensure a perfectly even surface. The finished surface shall be true and even and present uniform texture throughout and all joining marks shall be eliminated. All corners, edges and angles shall be made perfectly to line, plumb and square. All exposed angles and junction of walls, doors, windows, beams, slabs etc. shall be carefully finished so as to furnish a neat and even surface. Plastering items amongst all other things as described in various items also include:

1) Preparation of surface to receive the plaster, providing cement plaster of the specified average thickness and proportions with specified number of coats.

2) All labour, materials, scaffolding, use of tools and equipment to complete the plastering work as per specifications.

3) Curing for 10 days.

4) Cleaning the surface of doors, windows, floors or any other surfaces where plastering might have splashed.

5) Finishing the portion of plaster left above the terrazzo, Plain cement tiles, ironite or any type of skirting work to be finished rounded or as directed by the Engineer-in-charge, in a separate operation after laying of floor tiles skirting.

Sand Faced Cement Plaster :

General :

Materials and preparation of surfaces and scaffolding etc. for sand faced plaster wherever applicable shall conform to specification laid down herein before under section cement plastering and the following specifications are also to be complied with.

Preparation of Surface :

The surface to be plastered shall first be thoroughly cleaned down. All joints shall have been raked out in case of brick work/stone masonry as the work proceeds. Concrete surface shall also be clearly hacked and wire brushed if not already done before plastering is taken up. The surface to be plastered shall be well wetted for a minimum period of 6 hours before commencing the work. The mortar for all plaster work shall be cement sand mortar of mix as specified in the schedule of quantities. Double scaffoldings required for facility of construction shall be provided by the construction at his own expenses wherever directed by the Engineer-in-charge, Scaffolding shall be erected with pipes or bellies or bamboos of adequate strength so as to be safe for all the dead, live and impact loads likely to sustain by it during construction operations. The contractor shall take all measures to ensure the safety of the work and workmen. Any instruction of the Engineer-in-charge in this respect shall also be complied with. The contractor shall be entirely responsible for any damage to Government property or injury to persons, resulting from faulty scaffolding, defective ladders and materials or otherwise arising out of his default in this respect. Proper scaffolding shall be provided to allow easy approach for workmen and supervisory staff to every part of the work Ballies, Bamboos etc. for scaffolding shall not be tied to the windows, doors, mullions, ventilators etc. Any damage done to the windows, doors, etc. shall be made good by the contractor to the original conditions at his own cost. For better safety, steel pipe scaffolding is preferred.

Workmanship :

The surface to be plastered shall first be dubbed out with cement mortar to cover all irregularities and faces up to proud part. The dubbing coat which shall be of proportion as specified in schedule and a 12mm thick (1/2") layer shall then be applied/scored and keys shall be formed on the surface by thoroughly combing it with heavy horizontal lines about 12mm (1/2") apart and about 3mm (1/8") deep when mortar has just set. The cement mortar for sand faced plaster shall have washed and approved sand with slightly larger proportions of coarse materials, but not exceeding 3mm. The proportion of cement to sand shall be as specified in the schedule. The water is gradually added to make the mixture homogenous. The thickness of finishing coat excluding key

shall be 8mm (about 5/16"). After application the surface should be finished with a wooden float lined with a wooden float lined with cork closely pricked on with a wet sponge tapped gently to bring sand particles into prominence.

The chajjas and any other horizontal portions shall be cleaned and set mortar that might have been fallen at the time of plastering at higher elevation, before plastering the same is taken up. Vatas shall be done simultaneously with chajja plaster.

Mode of Measurement :

Area of plastering will be measured net and shall be paid for. The measurement of length of wall plastering shall be taken between walls or partitions (dimensions before plastering shall be taken) for the length and from top of the floor or skirting or dado as the case may be to the under side of ceiling for the height. All openings more than 0.1 sqm. shall be deducted and all jambs, so fits, sills of these openings if done, will be measured to arrive to the net area for payment. No opening less than 0.1 sqm. shall be deducted and no jambs etc. for such openings shall be measured for payment. The rate shall include the cost of finishing all the edges, corners, cost of all materials, labour, scaffolding, transport, curing etc. The rate shall include the cost of finishing all the edges, corners, cost of all materials, labour, transport, scaffolding, curing etc. and grooves if so specified in the item of schedule of quantities. The rate for plastering should include the cost of work towards the following items for co-ordination with electrical item:

*Neatly plastering around DB's junction boxes, M.S. boxes etc. should be done and made matching with the wall finish after installation of electrical equipment.

*All BD's service boxes, covers etc. should be covered by a plastic cloth of other suitable covering material such that water or materials should not splash the same during brick

work and plastering work. This is to be done in such a way that electrical equipment as well as painted surfaces are not spoiled.

*For fixing M.S. boxes, DB's etc. Thiya should be given such that the required face of the M.S. box, DB covers etc. in line with final finished plastered surface.

*The rate for the item shall also include rounding up of corner and angles making sharp corners and angles finishing around ceiling rose and electrical fittings etc. fixed by other agencies, finishing of top of dado and skirting (zad finishing), junctions of roof and wall or beam with the finish as specified in the item. Plastering of brick and concrete cornice and copings and plastering in restricted areas if any shall not be measured separately. Architectural bands and narrow widths of plaster over

structural as well as non-structural and the line when prepare dint eh same thickness of plaster shall not be measured separately and shall be covered by respective plaster items.

4.9 PAINTING

Scope of work:

The work covered under these specifications consist of furnishing the various types of paints and also the workmanship for these items, in strict compliance with these specifications, which are given in detail hereinafter with the item of schedule of quantities.

Materials:

Paints, oils varnishes etc. of approved brand and manufacture shall be used. Ready mixed paints as recovered from the manufacturer without any admixture shall be used. If for any reason, thinning is necessary in case of ready mixed paint, the brand of thinner recommended by the manufacturer or as instructed by the Engineer-in-charge shall be used. Approved paints, oils or varnishes shall be brought to the site of work by the contractor in their original containers in sealed condition. The materials shall be brought in at a time in adequate quantities to suffice for the whole work or atleast a fortnights work. The materials shall be kept in the joint custody of the contractor and the Engineer-in-charge. The empties shall not be removed from the site for work, till the relevant item of work has been completed and permission obtained from the Engineer-in-charge. The contractor shall associate the chemist of paint manufacturers before commencement of work, during and after the completion of work who shall certify the suitability of the surface to receive painting and the paint before use etc.

Commencing Work :

Scaffolding :

Wherever scaffolding is necessary, it shall be erected on double supports ties together by horizontal pieces, over which scaffolding planks shall be fixed. No bellies, bamboos or planks shall rest on or touch the surface which is being painted. Were ladders are used, pieces of old gunny bags shall be ties on their tops to avoid damage or scratches to walls. For painting of the ceiling, proper stage scaffolding shall be erected. Painting shall not be started until and unless the Engineer-in-charge has inspected the items of work to be painted, satisfied himself about their proper quality and given

his approval to commence the painting work. Painting, except the priming coat, shall generally be taken in hand after all other builders work, practically finished. The rooms should be thoroughly swept out entire building cleaned up atleast one day in advance of the paint work being started.

Preparation of Surface :

The surface shall be thoroughly cleaned. All dirt, rust, scales, smoke and grease shall be thoroughly removed before painting is started. Minor patches if any in plastered / form finished surfaces shall be repaired and finished in line and level in C.M/ 1:1 and cracks and crevices shall be filled with approved filler, by the contractor at no extra cost to the Department. The prepared surface shall have received the approval of the Engineer-in-charge after inspection, before painting is commenced.

Application :

Before pouring into smaller containers for use, the paint shall be stirred thoroughly in its containers. When applying also, the paint shall be continuously stirred in the smaller containers so that consistency is kept uniform. The external surfaces of the buildings under reference including the R.C.C. Jalli, fins and the panels above and the panels above and below the window etc. shall be finished in different colours of approved shade. The contractor will make suitable samples at site for Departments approval before taking up the work in hand and they will be allowed to proceed with the work only after getting Departments approval for the same. The painting shall be laid on evenly and smoothly by means of crossing and laying off, the later in the direction of the grain in case of wood. The crossing and laying off consists of covering the area with paint, brushing the surface hard for the first time and then brushing alternately in opposite directions two or three time and then finally brushing lightly in direction at right angles to the same. In this process, no brush marks shall be left after the laying off is finished. The full process of crossing and laying will constitute one coat. Where so stipulated, the painting shall be done with spraying. Spray machine used may be

(a) a high pressure (small air aperture) type or

(b) a low pressure (large air gap) type,

depending on the nature and location of work to be carried out. Skilled and experienced workmen shall be employed for this class of work. Paints used shall be brought to the requisite consistency by adding a suitable thinner. Spraying should be done only when dry condition prevails. Each coat shall

be allowed to dry cut thoroughly and rubbed smooth before the next coat is applied. This should be facilitated by thorough ventilation.

Each coat except the last coat, shall be tightly rubbed down with sand paper or fine pumice stone and cleaned of dust before the next coat is laid. No left over paint shall be put back into the stock tins. When not in use, containers shall be kept properly closed. The final painted surface shall present a uniform appearance and no streaks, blisters, hair marks from the brush or clogging of paint puddles in the corners of panels, angles of moldings etc. shall be left on the work. In case of cement based paints / primers, the absorbent surfaces shall be evenly damped so as to give even suction. In any weather, freshly painted surfaces shall be kept damp for at least two days. In painting doors and windows, the putty around the glass panes must also be painted, but care must be taken to see that no paint stains etc. are left on the glass. Tops of shutters and surfaces in similar hidden locations shall not be left out while painting. Prospect covers of electrical switch boxes have to be painted from inside by removing them. Care shall be taken while removing them in position after painting with respective approved paints. In painting steel work, special care shall be taken while painting over bolts, nuts, rivets, overlaps etc. The additional specifications for primer and other coats of paints shall be as in accordance to the detailed specifications under the respective headings. Any damage caused during painting work to the existing works / surfaces shall be made good by the contractor at his own cost.

Brushes and Containers :

After work, the brushes shall be completely cleaned off paint and linseed oil by rinsing with turpentine. A brush in which paint has dried up is ruined and shall be kept at a place free from dust. When the paint has been used, the containers shall be washed with turpentine and wiped dry with soft clean cloth, so that they are clean and can be used again.

Measurement :

Painting, unless otherwise stated shall be measured by area in square metre. Length and breadth shall be measured correct upto two places of decimal of a meter. No deduction shall be made for opening not exceeding 0.05 sqm. and no addition shall be made for painting to the beading, moulding edges, jambs, soffits, sills, architraves etc. of such openings. In measuring painting, varnishing, oiling etc. of joinery and steel work etc. the coefficient as in the following table shall be used to obtain the areas payable. The coefficient shall be applied to the areas measured flat and not

girthed in all cases. In case of painting of door shutter with push plates in plastic laminate, deduction will be made for area of such laminations.

Precautions :

All furniture, lightings, fixture, sanitary, fittings, glazing, floors etc. shall be protected by covering and stains, smears, splashing, if any shall be removed and any damage done shall be made good by the contractor at his cost.

Rates :

Rates shall include cost of all labour and materials involved on all the operations described above and in the particular specifications given under the several items.

Painting, Priming coat on Wood, Iron of Plastered Surfaces

Primer

The primer for wood work, iron work or plastered surface shall be as specified in the description of the item. Primer for wood work / Iron & Steel / Plastered / Aluminium surfaces shall be as specified below:

Surfaces Primer to be used

- a) Wood work (hard and soft wood) Pink conforming to IS 3536 – 1966
- b) Resinous wood and ply wood Aluminium Primer
- c) Iron & Steel, aluminium and galvanized steel Work : Zinc chromate primer conforming to IS 104-1962
- d) d) Plastered surfaces, cement brick work, Asbestos surfaces for oil bound distemper and paint Cement primer The primer shall be ready mixed primer of approved brand and manufacture.

The wood work to be painted shall be dry and free from moisture. The surface shall be thoroughly cleaned. All unevenness shall be rubbed down smooth with sand paper and shall be well dusted. Knots, if any, shall be covered with preparation of red lead

made by grinding red lead in water and mixing with strong glue sized and used hot. Appropriate filler material with same shade as paint shall be used where so desired by the Engineer-in-charge. The surface treated for knotting shall be dry before painting is applied. After the priming coat is applied, the holes and indentation on the surface shall be stopped with glaziers putty or wood putty (for specifications for glaziers putty and wood putty – refer as mentioned herein before). Stopping shall not be done before the priming coat is applied as the wood will absorb the oil in the stopping and the latter is therefore liable to crack.

Iron and Steel Work :

All rust and scales shall be removed by scrapping or by brushing with steel wire brushes. Hard skin of oxide formed on the surface of wrought iron during rolling which becomes loose by rusting, shall be removed. All dust and dirt shall be thoroughly wiped away from the surface. If the surface is wet, it shall be dried before priming coat is undertaken.

Plastered Surface :

The surface shall ordinarily not be painted until it has dried completely. Trial patches of primer shall be laid at intervals and where drying is satisfactory, painting shall be taken in hand. Before primer is applied, holes and undulations, shall be filled up with plaster of Paris / putty and rubbed smooth.

erintendent Engineer for his circle every year and approved by the Board of Chief Engineers. These rates are incorporated in the standard schedule of rates.

Lead statement:

The distance between the source of availability of material and construction site is known as "Lead " and is expected in Km. The cost of conveyance of material depends on lead. This statement will give the total cost of materials per unit item. It includes first cost, conveyance loading, unloading stacking, charges etc. The rate shown in the lead statement are for metalled road and include loading and staking charges. The environment lead on the metalled roads are arrived by multiplying by a factor

- a) for metal tracks - lead x 1.0
- b) For cartze tracks - Lead x 1.1
- c) For Sandy tracks - lead x 1.4

Note: For 1m³ wet concrete = 1.52m³ dry concrete approximately

SP.Wt of concrete= 1440 kg/m³ (or) 1.44 t/m³

1 bag of cement = 50 Kg

UNIT-V VALUATION

OBJECTS OF VALUATION

DEFINITIONS

Market Value

Book Value

Capital cost

Sinking Fund Method

Direct comparison with the capital Value

Depreciation Method of Valuation

Methods for calculating depreciation

FIXATION OF RENT CALCULATION OF STANDARD RENT OF A GOVT. PROPERTY TECHNICAL TERMS

1. EXPENDITURE

The whole amount can be spent during the financial year or not.

2. CAPITAL COST

Total cost including all the expenditure incurred from beginning to the completion of a work.

3. PROVISIONAL SUM

Estimate of bill quantities for some special work to be done by a specialist firm whose details are known at the time of preparation of estimate.

4. RATE OF COST

The cost per unit of subhead which is arrived at by dividing the up-to-date final charges on a sub-head by its up-to-date progress.

5. PREMIUM

The tendered percentage rate above the notified rates.

6. REBATE

The tendered percentage rate below the notified rates.

7. PLINTH AREA

It is a covered area of a building measured at floor level. It is measured by taking external dimensions excluding plinth offset if any.

8. RATES

Rates followed are of sanctioned schedule of rates or nonscheduled, this fact is to be mentioned under this sub – head.

9. CONTINGENCIES

Incidental expenses of miscellaneous character which cannot be classified approximately under any distinct sub-head, but is added in the cost of construction necessarily.

10. VALUATION

Valuation is the technique of estimating or determining the fair price or value of a property such as building, a factory, other engineering structure of various types, land... etc.

12. SALVAGE VALUE

It is the value of end of utility period without being dismantled.

SINKING FUND

The fund is gradually accumulated by way of periodic on annual deposit for the replacement of the building or structure at the end of its useful life.

DEPRECIATION

Depreciation is the gradual exhaustion of a usefulness of a property. Decrease or loss in the value of a property due to its structural deterioration use, life wear and tear, decay and obsolescence.

SCRAP VALUE

Scrap value is the value of dismantled materials. For a building when the life is over the end of utility period of dismantled materials as steel, bricks, timber. Etc. will fetch certain amount which is scrap value of a building.

5.1 OBJECTS OF VALUATION

It is the technique of estimating and determining the fair price or value of a property such as a building, a factory or other engineering structures of various types, land etc.

5.1.1 Six important Purposes of Valuation:

The main purposes of valuation are as follows:

Buying or Selling Property

When it is required to buy or sell a property, its valuation is required.

Taxation

To assess the tax of a property, its valuation is required. Taxes may be municipal tax, wealth tax, Property tax etc, and all the taxes are fixed on the valuation of the property.

Rent Function

In order to determine the rent of a property, valuation is required. Rent is usually fixed on the certain percentage of the amount of valuation which is 6% to 10% of valuation.

Security of loans or Mortgage

When loans are taken against the security of the property, its valuation is required.

Compulsory acquisition

Whenever a property is acquired by law; compensation is paid to the owner. To determine the amount of compensation, valuation of the property is required.

Valuation of a property is also required for **Insurance, Betterment charges, speculations** etc.

Valuation of Building:

Valuation of a building depends on the type of the building, its structure and durability, on the situation, size, shape, frontage, width of roadways, the quality of materials used in the construction and present day prices of materials. Valuation also depends on the height of the building, height of the plinth, thickness of the wall, nature of the floor, roof, doors, windows etc.

The valuation of a building is determined on working out its cost of construction at present day rate and allowing a suitable depreciation.

Six Methods of Valuation

1. Rental Method of Valuation
2. Direct Comparisons of the capital value
3. Valuation based on the profit
4. Valuation based on the cost
5. Development method of Valuation
6. Depreciation method of Valuation

5.2 DEFINITIONS

a) Market Value

The market value of a property is the amount which can be obtained at any particular time from the open market if the property is put for sale. The market value will differ from time to time according to demand and supply.

The market value also changes from time to time for various miscellaneous reasons such as changes in industry, changes in fashions, means of transport, cost of materials and labour etc.

b) Book Value

Book value is the amount shown in the account book after allowing necessary depreciations. The book value of a property at a particular year is the original cost minus the amount of depreciation allowed per year and will be gradually reduced year to year and at the end of the utility period of the property, the book value will be only scrap value.

c) Capital cost

Capital cost is the total cost of construction including land, or the original total amount required to possess a property. It is the original cost and does not change while the value of the property is the present cost which may be calculated by methods of Valuation.

Capitalized Value of a Property

The capitalized value of a property is the amount of money whose annual interest at the highest prevailing rate of interest will be equal to the net income from the property. To determine the capitalized value of a property, it is required to know the net income from the property and the highest prevailing rate of interest.

Therefore, Capitalized Value = Net income x year's purchase

Year's Purchase

Year's purchase is defined as the capital sum required to be invested in order to receive a net receive a net annual income as an annuity of rupee one at a fixed rate of interest.

The capital sum should be $1 \times 100 / \text{rate of interest}$.

Thus to gain an annual income of Rs x at a fixed rate of interest, the capital sum should be $x(100/\text{rate of interest})$.

But $(100/\text{rate of interest})$ is termed as Year's Purchase.

The multiplier of the net annual income to determine the capital value is known as the Year's Purchase (YP) and it is useful to obtain the capitalized value of the property.

5.2.4 Sinking Fund Method

In this method, the depreciation of a property is assumed to be equal to the annual sinking fund plus the interest on the fund for that year, which is supposed to be invested on interest bearing investment. If A is the annual sinking fund and $b, c, d, \text{ etc.}$ represent interest on the sinking fund for subsequent years and $C = \text{total original cost}$, then –

Rental Method of Valuation

In this method, the net income by way of rent is found out by deducting all outgoing from the gross rent. A suitable rate of interest as prevailing in the market is assumed and Year's purchase is calculated. This net income multiplied by Year's Purchase gives the capitalized value or valuation of the property. This method is applicable only when the rent is known or probable rent is determined by enquiries.

5.2.5 Direct comparison with the capital Value

This method may be adopted when the rental value is not available from the property concerned, but there are evidences of sale price of properties as a whole. In such cases, the capitalized value of the property is fixed by direct comparison with capitalized value of similar property in the locality.

Valuation based on profit

This method of Valuation is suitable for buildings like hotels, cinemas, theatres etc for which the capitalized value depends on the profit. In such cases, the net income is worked out after deducting gross income; all possible working expense, outgoings, interest on the capital invested etc. The net

profit is multiplied by Year's Purchase to get the capitalized value. In such cases, the valuation may work out to be high in comparison with the cost of construction.

Valuation based on cost

In this method, the actual cost incurred in constructing the building or in possessing the property is taken as basis to determine the value of property. In such cases, necessary depreciation should be allowed and the points of obsolescence should also be considered.

Development Method of Valuation

This method of Valuation is used for the properties which are in the underdeveloped stage or partly developed and partly underdeveloped stage. If a large place of land is required to be divided into plots after providing for roads, parks etc, this method of valuation is to be adopted. In such cases, the probable selling price of the divided plots, the area required for roads, parks etc and other expenditures for development should be known.

If a building is required to be renovated by making additional changes, alterations or improvements, the development method of Valuation may be used.

5.2.6 Depreciation Method of Valuation

According to this method of Valuation, the building should be divided into four parts:

1. Walls
2. Roofs
3. Floors
4. Doors and Windows

And the cost of each part should first be worked out on the present day rates by detailed measurements.

The present value of land and water supply, electric and sanitary fittings etc should be added to the valuation of the building to arrive at total valuation of the property.

Depreciation is the gradual exhaustion of the usefulness of a property. This may be defined as the decrease or loss in the value of a property due to structural deterioration, life wear and tear, decay and obsolescence.

5.2.6.1 Methods for calculating depreciation

1. Straight line Method
2. Constant percentage method
3. Sinking Fund Method
4. Quantity Survey Method

Straight Line Method

In this method, it is assumed that the property loses its value by the same amount every year. A fixed amount of the original cost is deducted every year, so that at the end of the utility period, only the scrap value is left.

Annual Depreciation, $D = (\text{original cost of the asset} - \text{Scrap Value})/\text{life in years}$

For example, a vehicle that depreciates over 5 years, is purchased at a cost of

US\$17,000, and will have a salvage value of **US\$2000**, will depreciate at **US\$3,000** per year:

$(\$17,000 - \$2,000) / 5 \text{ years} = \$3,000$ annual straight-line **depreciation expense**. In other words, it is the **depreciable cost** of the asset divided by the number of years of its useful life.

Constant Percentage Method or Declining balance Method

In this method, it is assumed that the property will lose its value by a constant percentage of its value at the beginning of every year.

Annual Depreciation, $D = 1 - (\text{scrap value}/\text{original value})^{1/\text{life in year}}$

Quantity Survey Method

In this method, the property is studied in detail and loss in value due to life, wear and tear, decay, and obsolescence etc, worked out. Each and every step is based on some logical grounds without any fixed percentage of the cost of the property. Only experimental valuer can work out the amount of depreciation and present value of a property by this method.

5.3 FIXATION OF RENT

Capitalized value of the property can be known by any of the methods discussed earlier and suitable value of year's purchase is adopted according to the admissible rate of interest (8% or any other fair rate).

Then, Net income = capitalized value / year's purchase

All possible outgoings are added to this net income which will give gross income from the property.
Gross income or gross rent = Net rent + outgoings

The standard rent = (Gross Income / 12) per month.